

Alternatives for Navigating Small Unmanned Air Vehicles without GPS

Ramsay Talmadge, Luke Jenkins, Drew Hidalgo, Josh Olivas, and Roger Burk

Department of Systems Engineering
United States Military Academy
West Point, NY

Corresponding author's Email: roger.burk@usma.edu

Author Note: The first four authors of this document were cadets in the Systems Engineering Department at the United States Military Academy, West Point, in the Class of 2016. Dr. Burk was their faculty advisor for this project. The client was Mr. Lars Ericsson of Army Project Manager Unmanned Aircraft Systems (PM UAS).

Abstract: Considering the increased reliance on GPS navigation for the Army's Unmanned Aircraft Systems, adversaries have invested in capabilities to deny our systems access to genuine GPS signals. Although significant effort has been put forth in the areas of anti-jamming and anti-spoofing in GPS receivers, a need for alternative navigation methods in a GPS denied environment has grown in importance. This report outlines the recommendation and analysis completed for Mr. Lars Ericsson of the Army Project Manager Unmanned Aircraft Systems (PM-UAS). The report includes background research in the domain space, comprehensive stakeholder analysis, derived system requirements and functional requirements, ending with alternative generation, value scoring, costing, and provided findings for a recommended alternative for future consideration.

Keywords: Small Unmanned Aircraft Systems (SUAS), GPS Navigation, GPS Alternatives, Systems Decision Process

1. Introduction

1.1 Background

Dunnigan describes how the United States military is increasingly reliant on unmanned aircraft systems (UAS) in order to meet its reconnaissance and targeting goals worldwide as well as to conduct dull, dangerous, or dirty missions that would be difficult for manned aircraft to perform. The United States' adversaries are aware of the prevalence of UAS and they are doing everything they can to limit the advantages UAS's provide. A vulnerable point of the systems is the GPS navigation systems. Rival nations now possess the capability to build powerful jamming devices or conduct sophisticated spoofing attacks to limit the UAS ability to navigate. In addition to state threats, asymmetric insurgent groups can now afford simple GPS jamming devices. Therefore, the United States military is looking for alternative methods that UAS can use to navigate (Dunnigan, 2013).

1.2 Problem Statement

Research, evaluate, and provide a recommendation to PM-UAS for possible and emerging possible alternatives for accurate position, navigation, and timing in a GPS denied environment, for the Army's Small Unmanned Aircraft Systems (SUAS), Puma and Raven.

1.3 Recommendation to Client

At the conclusion of the analysis found in this paper, the PM-UAS capstone team recommends a multi-GNSS receiver capable of acquiring multiple GNS systems used by varying nations. Further discussed in the follow on sections, this recommendation meets the criteria and functionality derived from significant analysis and provides reliable PNT alternatives to GPS for the Army's small unmanned aircraft.

1.4 Report Outline and Analysis Method

To conduct the analysis of alternatives for GPS denied navigation, the PM-UAS capstone team applied the System Decision Process, taught at the United States Military Academy and found in Decision Making in Systems Engineering and Management by Parnell, Driscoll, and Henderson. The process starts with a problem definition phase where significant research, stakeholder analysis, and functional analysis comprehensively develops the problem statement and system that is necessary to meet the objective outcomes. From problem definition, the process moves to the solution design, where idea generation, alternative generation and scoping, and feasibility screening are completed to develop solutions and focus the scope of detailed analysis. The process moves into the decision making phase, where each alternative is scored on a normalized scale. Additionally, costing considerations and sensitivity analysis of changes in priorities are completed resulting in a comprehensive recommendation to the client. The process would apply one more phase, Implementation phase, however is out of the scope of this analysis. The following report applies this phased structure as the paper format, leading the reader through the process applied, providing the completed analysis along the way.

2. Problem Definition

Within the problem definition phase, the team conducted significant domain research, stakeholder analysis, and functional analysis, found in the following subsections.

2.1 Domain Research

As part of the domain research phase, comprehensive literature reviews were completed in order to properly understand the domain space surrounding GPS navigation and more specifically GPS denied navigation. Each team member conducted a specific area of research and briefed the team on their findings to develop sound situational awareness across the team analysts. The following synopses discuss the research conducted and the conclusions made.

Cadet Luke Jenkins conducted research related to the current U.S. based NAVSTAR GPS system for worldwide civilian and military PNT coverage. The literature review covered dissertation work conducted at the Air Force Institute of Technology, found on the Defense Technical Information Center, as well as other informational online platforms such as GPS.gov and reputable news agencies. The crux of the research related to the operational capacity and technical specifications of GPS signals in order to identify the vulnerabilities related GPS. The current NAVSTAR system emits two pseudo code signals the Coarse/Acquisition code (C/A) and Precision (P) code with encryption indicated as P(Y) code. The current 27 satellite constellation emits these two signals on the L1, L2, and L5 bands. The system works by aligning the genuine pseudo random code from the satellite with the GPS receiver. This process allows the receiver to sync with the atomic clock information and use the ranging signals to calculate an accurate distance from a minimum of 4 geo-synchronized satellites (GPS, 2015). Within this system specific vulnerabilities expose the system to disruptions. Due to the constellation flying at over 12,000 miles above the earth's surface the emitted signal is weak at the point in which it is received by the receiver. This low decibel level creates a susceptibility to noise jamming that can deny access to genuine GPS signal. Secondly, the weak signal creates natural disruptions like sky blockage enabled by thick foliage or urban and terrain disruptions that block receiver's ability to gain a reliable lock. In addition to these vulnerabilities, GPS signals, most specifically the C/A code is susceptible to a spoofing attack. In this attack, genuine code is forged by a false emitter and used to deceive GPS receivers on their true location. This attack can be used to disrupt PNT capabilities as well as used to mislead or capture devices utilizing GPS as their primary means of navigation. Lastly, the NAVSTAR system does have a level of susceptibility to natural disruptions coming from malfunctioning equipment. Overall, the research conducted by Cadet Luke Jenkins concluded that GPS is not a secure system and thereby, reliable alternatives that are not susceptible to the same vulnerabilities, are needed to ensure reliable PNT is available in a GPS denied environment (Adams, 2000).

Cadet Ramsay Talmadge conducted research relating to the Army's premiere strategic level UAS the MQ-1C Gray Eagle and the RQ-7 Shadow. This research was valuable for understanding unmanned aircraft operations and the Army's UAS programs in general. However, the focus of the project turned away from these two platforms to the smaller SUAS: AeroVironment's PUMA and RAVEN. The smaller systems have very different payload capabilities. This shift in focus was in response to the client's wishes (Sasidharan, 2014) (Wasserbly, 2014).

Cadet Olivas conducted research for the team on the Inertial Navigation System (INS). This was a necessary area of research because it was a possible alternative outlined by the primary stakeholders. At a basic level, INS is made up of two types of sensors, an accelerometer and a gyroscope, and a computer. The computer takes the sensory information and inputs it into an algorithm to compute location. However, there is an issue with compounding error over time as small inaccuracies

in the sensors leads to computation errors which leads to further computation errors based on a previously incorrect location calculation. The level of error varies based on the quality of the sensors but can be as small as 1 NM/h (Schmidt, 2015). Currently, INS is used as a supplement to GPS-based navigation. There are three different types of GPS/INS integration: loosely-coupled, tightly-coupled, and deep integration (Schmidt, 2015). These systems, however, are simply to supplement and error correct for the GPS which is not the scope of the problem PM UAS is trying to solve. Rather, at least at this point, the scope of the problem seems to be how to navigate an UAS when GPS is being completely denied to that aircraft. In order to alleviate that error, research has been done in how to reduce the error found in INS. One example is the incorporation of an inertial sensor, a magnetometer, and nonholonomic constraints into the INS. Incorporating these three things seems promising as research found that it reduced calculating error by 50% (Won, 2015). A different example of a researched advancement is the use of the laser Doppler velocimeter. In testing, the system yielded results of a twenty meter error in two hours from a baseline error of 1166m in two hours with pure strap-down INS (Zhou, 2014). These are just two examples of many research experiments being conducted to try and improve the system.

Cadet Drew Hidalgo focused his research efforts on pseudolites for background knowledge development of alternatives that are not integrated into the physical SUAS. Pseudolites are ground level satellites that a SUAS can detect as actual satellite signals. Pseudo Satellites or “Pseudolites” actually predate existing satellites. These ground based satellites were used in the first experiments that would eventually lead to the development and employment of the 24 satellites we use every day for GPS navigation (Oktay, 2011). Pseudolites provide the same signals that are produced by satellites but originating from ground stations. Pseudolites provide a much stronger signal than satellites and therefore can combat against denial methods such as noise jamming by overcoming the jamming signal’s decibel level. These systems have also been used to provide a GPS signal for vehicles that are in areas where satellite signals are blocked by the natural environment such as by mountains or trees. Moreover, integration of these systems provide an increased level of accuracy when combined with other technologies (Oktay, 2011). The Product Director: Positioning, Navigation, and Timing is currently developing a system of pseudolites that can be deployed either on ground or on water based vehicles to allow military receivers to receive a stronger broadcast on the L1 and L2 bands. This project has yet to physically manifest itself, however, PD PNT has announced on its website that it plans to expand the application of pseudolites for ground based operations. There was no new information found after gaining access to some of their For Official Use Only documents. It is likely that the PD PNT pseudolites project is still in its infancy stages. Pseudolites are among the merging possible technologies that can be applied to SUAS systems.

2.2 Concept of Operations

Derived from the problem statement, an operational scenario was produced to conceptualize the environment and identify the needs of the SUAS navigation systems. An operational concept diagram was produced to describe this scenario, which is found in Figure 1. In this scenario, the SUAS navigates into an area in which GPS is being degraded by an enemy force. In order to maintain mission capable status, the system automatically assesses the GPS signal and transitions the position, navigation, and timing (PNT) source to the selected alternative, allowing the vehicle to continue mission. This automatic process of evaluating and applying the best PNT source continues through the duration of the mission. As shown, the system shall integrate a GPS module, integration controller, and a module for the alternative PNT source. This three-component system will enable the vehicle to autonomously evaluate and select the most reliable PNT source as its method of navigation.

Given the recommended alternative, the SUAS will transition between different GNSS as necessary. The selection between particular GNSS will depend on whether each system has been degraded by jamming or spoofing and the number of satellites available locally per system. While GNSS are globally available, many are still regionally focused. For instance, BeiDou will typically have superior coverage in the Far East Pacific region while GLONASS will likely remain superior in Eastern Europe even as more satellites come on line for all systems. Ideally, the multi GNSS PNT system will periodically check with all GNSS systems to check availability, but it will not constantly navigate with all systems in order to prolong battery life. The multi GNS system could also be used to provide the necessary error corrections to an onboard inertial navigation unit to give the SUAS incredibly robust navigation capability.

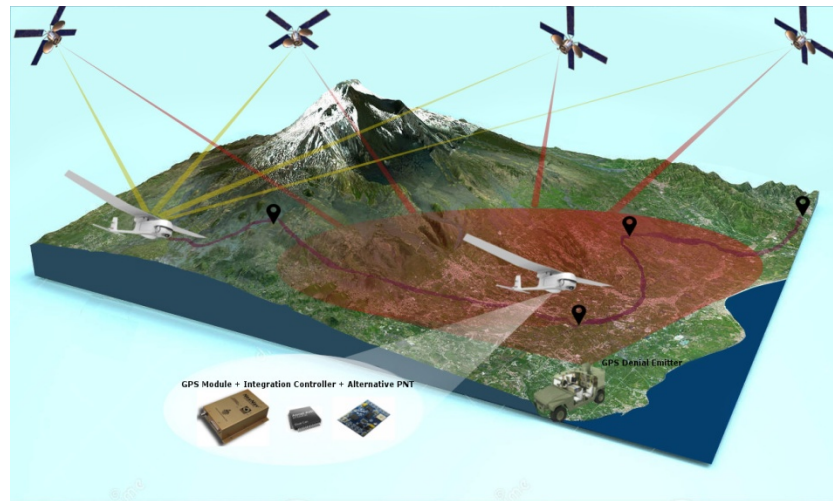

Figure 1: GPS Denied Navigation Operational Concept

2.3 Stakeholder Analysis

Significant stakeholder analysis was conducted in order to properly complete the problem definition phase. The analysis conducted included identifying all relevant stakeholders, their needs, wants, and desires, and then formally translating those into stakeholder requirements for the alternative PNT source (Parnell, 2008). For the SUAS navigation system PM-UAS is identified as the client and decision maker. The consumers of the system were identified as the United States Army acquisition corps, and the users include land force soldiers as well as all other parties requiring reliable intelligence, surveillance, and reconnaissance (ISR). These groups of individuals were engaged through interviews, request for information, and research.

The most important source of information was Mr. Lars Ericsson, the team's contact at PM-UAS. Mr. Ericsson provided recommendations, validated requirements, answered RFIs, and provided contact info for specific experts in relevant fields. For information regarding the SUAS themselves, Mr. David Hendrickson of AeroVironment provided invaluable data through emails and an extensive interview. Major Heather Ritchie provided information regarding end use from a company commander's perspective. Rakesh "Teddy" Kumar and Kevin Bush from SRI International provided extensive information regarding visual navigation technology and procedures. Manufacturers in the GNSS receiver industry were contacted regarding the specifics of the products they offered.

Once engaging the relevant stakeholders, their needs, wants, desires, and information were translated into stakeholder requirements which represent the view of the services thought to be needed by the stakeholder within the defined operational environment. The stakeholder requirements are the first step in translating requirements of the system in to functional components of the system. The requirements derived from the relevant stakeholders are included in Table 1.

2.4 Requirements Analysis

Operational and system requirements were developed in order to translate the stakeholder requirements into functional requirements of the system. The stakeholder requirements were first operationalized by applying the requirements to the operational scenario and determining what requirements must be met in order for the system to conduct the desired operation. Once identifying the key operational components, system specific requirements were developed. These system requirements include specifics on size, weight and power (SWaP), availability, integrity, continuity, and accuracy of the alternative. In addition to aiding the functional analysis of the system, these system requirements aid in the development of the quantitative evaluation of the system.

Table 1: Requirements Traceability Matrix

Stakeholder Requirement	Stakeholder	Qualitative Value Measure	Function
1. Alternative must function in the absence of GPS	PM-UAS	Navigate Accurately	2.0, 4.0, 5.0
2. Alternative must meet SWaP requirements of SUAS	PM-UAS, AeroVironment	Operate within power, weight, size constraints	1.0,5.0
3. (If Applicable) System should have a <.4 km drift per hour	PM-UAS	Navigate Accurately	3.0
4. Alternative should cost between \$2000-\$5000, objective and threshold respectively	PM-UAS	N/A	N/A
5. Alternative should have an objective accuracy of 10m with 90% confidence & threshold of 100m with 90% confidence	PM-UAS, SRI	Navigate Accurately	3.0
6. Alternative should be available within 10 years	PM-UAS	Technical Readiness Level	5.0

2.5 Functional Analysis

Derived from the stakeholder and operational requirements are the system functions. The functions were first identified through a functional hierarchy. The functional hierarchy shown in Figure 2 determined the fundamental objective of the system is to be able to conduct a tactical reconnaissance mission in a GPS denied environment. To meet this objective tier one functions were developed that enabled the desired function. Seen in the first level of functions in Figure 2 the functions span from the launch of the UAS to the completion of the mission and return to base. This ensures the functions are traced back to requirements that enable vehicle to be launched, operated through GPS available and GPS denied environments, complete the mission, and return to base. For example, the Launch UAS function can be traced back to the system level requirements for size, weight, and power to ensure the UAS is capable of taking flight. The traceability of these functions is included in Table 1 in the Stakeholder Analysis section.

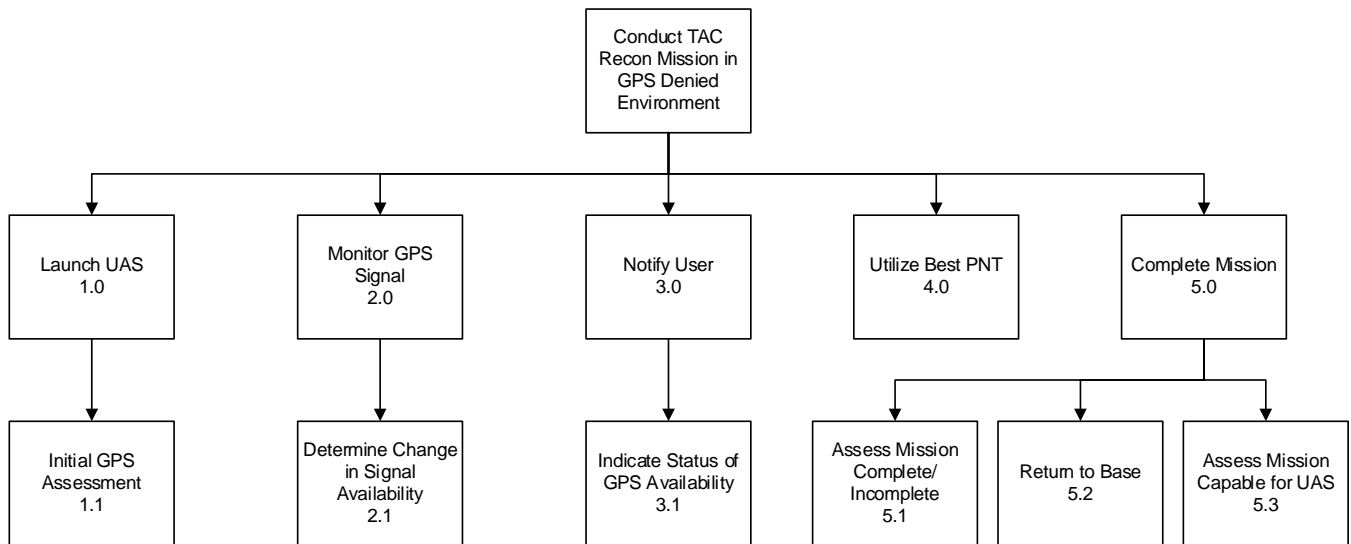

Figure 2: Functional Hierarchy

Using these derived functions, a functional flow block diagram (FFBD) was developed as depicted in Figure 3. The FFBD shows the expected function set in order to launch the UAS, operate and navigate through a GPS denied environment, successful complete the mission, and return to base. The important takeaways from the FFBD are the parallel functions and feedback loops. This shows that the system is meant to be continuously running, continuously monitoring the GPS signal quality and assessing the best PNT source to use. As a continuous process, the system shall be able to select an alternative

source of PNT seamlessly when GPS has become degraded to the point where it is unreliable. The only indication the system is now navigating off an alternative source is the notification sent to the user that it has switched. The xyz denotes placeholder values that have not changed from the functional hierarchy.

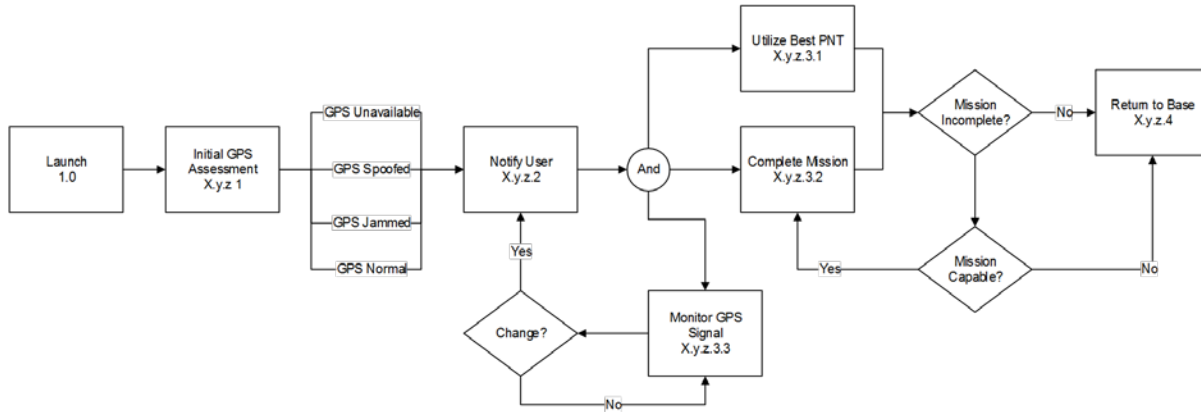

Figure 3: Functional Flow Block Diagram

3. Solution Design

3.1 Idea Generation

Idea Generation describes the initial research into possible technologies or methodologies that the team sees as a possibility no matter how obscure it may seem initially. During this phase any and all ideas are generally considered. Extensive data searches were conducted by the team on multiple data bases from civilian and Department of Defense accounts. Additionally, the team conducted these searches individually in order to ensure the best use of man hours. At the end of the time blocked for the idea generation phase the team came together to compare each other's findings. Between the four of us we had fourteen legitimate alternatives to begin an in-depth analysis of.

The alternatives put forth came from recommendations by the client or were found through research and subsequent knowledge of the field. The initial list of alternatives was: Inertial Measurement Unit (IMU), Timing Inertial Measurement Unit (TIMU), eLoran, Navigational Signals of Opportunity (NAVSOP), Known Satellites, M-Code GPS, Psuedolites, Anti-Jamming Antenna (AJ), Celestial Navigation, Visual Mapping, TRE-G3TAJT, and Operational Changes. It is assumed that the team could implement several combinations of these as an alternative as well.

IMUs use input from magnetometers and accelerometers to calculate the location assuming a known start point. They are currently employed in many commercial SUAS's and are also prominent in many tactical missiles most notably Intercontinental Ballistic Missiles (ICBM's). IMU's require no signal to operate outside of an initial reference point. The caveat to IMU's is that they incur a drift over time from the actual position due to small errors in the measurements taken from the magnetometers and accelerometers. TIMUs work similarly but instead use a more accurate sensor. TIMU's are significantly smaller than the traditional IMU (about the size of a penny) and are most powerful when linked with two or three other TIMU's. This technology is still under heavy development by DARPA. eLoran is a system of distributed ground emitters that broadcast low frequency signals which allows the receiver to calculate its location (Basker, 2007). The infrastructure for this type of signal still remains relatively intact after it was deactivated in support of the new GPS sytem being put into place. NAVSOP uses any known signal, such as radio station broadcasts, WIFI, etc. to calculate a location. M-Code GPS is the next generation of GPS signal being implemented by the United States. These provide the most opportunities for a receiver to find a signal and orient it. A BAE system is working further developing this system to meet operational requirements. TRE-G3TAJT is a receiver that monitors several GNSS signals, such as GPS, Globalnaya Navigazionnaya Sputnikovaya Sistema (GLONASS), BeiDou and Galileo at the same time in order to determine location. It can use multiple different signals in order to develop more comprehensive navigation. (JAVAD GNSS, 2016) Multi-GNS Systems are already a well developed market that is proven in other technologies such as GPS watches. The team also considered a non-technological approach to the GPS-denied problem. The cost of acquisition would be considerably less if

there was a non-technological solution available. Retraining would be the most time and cost intensive measure for changing doctrine. This approach would involve research into doctrine about operating procedures of SUAS flights and when GPS becomes unavailable.

3.2 Solution Enhancement

In order to improve the value of any of these alternatives, the team assumed that they all could, and would, be augmented by GPS when actually implemented in the system. In other words, we would not be abandoning GPS as the primary means of navigation for the UAS. The other enhancement we made to the selection of alternatives was to analyze the TRE-G3TAJT commercially available receiver instead of the larger TRE-3 because it performed better at meeting the clients SWaP requirements. Both are in the same line of products from JAVAD GNSS Inc. Furthermore, we sought to research the methodology behind the TRE-G3TAJT to see if there were any technologies that use the same ideas. The team then expanded this method to all of our proposed alternatives in order to provide the most holistic view of each alternative as possible.

Additionally, the team sought to combine some of the alternatives in order to enhance the overall availability of navigation signals. The team sought to enhance GPS with the IMU, TIMU and NAVSOP. Each of these alternatives alone has their limits but can provide redundancy for GPS especially in GPS denied environments. The IMU and TIMU enhancements will help reduce an excessive drift rate associated with the technology when coupled with GPS. The GPS will provide an accurate location to the IMU/TIMU during non-denied stages in the operation. NAVSOP will also enhance GPS in a similar way. It will provide accurate location when GPS is not available and switch between the two at will.

3.3 Feasibility Screening

Feasibility screening is a systems engineering method that combines the gathered information of the researchers and the stakeholders requirements in order to eliminate unfit alternatives from future evaluation. This is the first part of analysis conducted on the proposed alternatives. Feasibility screening is largely a qualitative analysis. Each alternative is subject to the same number of stakeholder requirements. If an alternative fails any of the requirements the alternative receives a "NO GO."

3.3.1 Inertial Alternatives

IMU, INS, and TIMU are all inertial systems that were evaluated on guidance from PM-UAS. Although units at this size and cost are likely to produce a 5 nm/hr drift rate (VectorNav), exceeding the standards for accuracy, the alternatives were retained for further analysis. The reason for retention was the ability for IMU systems to be error corrected through GPS error correction. Additionally, TIMU suggests that one unit will have less than a 1km/hr error. The miniaturization of this technology will also allow SUAS's to carry multiple TIMU's onboard that will enable it to compound its effects and reduce the overall error. However, the TIMU has either kept a low profile since its last update or has been scrapped all together. The team assessed the TRL level of the TIMU as being ready within the next ten years but there is a lot of error that is associated with that assumption.

3.3.2 Signal Alternatives

Multiple signal based alternatives were evaluated. The first alternative, NAVSOP was screened due to integrity issues. This technology catalogs signals for use in navigation, therefore when signatures change, integrity is lost. Known Satellites were screened out for similar reasons as many of the available satellites do not emit GNSS usable information. M-Code GPS is the slotted replacement for the current P-Code system. However, a full spectrum of M-Code satellites are not predicted to be operational within the ten year developmental threshold thus it was screened out. Anti- Jam antennas have applicability for increasing GPS receiving strength. However, the most effective AJ antennas do not meet SWaP requirements for SUAS. eLoran was the first signal alternative to be retained for further analysis. The eLoran system builds upon the now decommissioned Loran-C system. Although requiring, fixed ground transmission stations, eLoran meets the requirements for aviation navigation today, making it a viable alternative for further consideration. Pseudolites were presented to the team with a relatively heavy emphasis by the client. We did extensive research into the different kinds of pseudolites that are currently being produced. We found that these ground-based, portable satellites provide a very strong signal that is exceedingly difficult to jam or even spoof. However, they do pose a security threat if left unattended on the ground. Additionally, pseudolites are being developed for aerial applications that are not feasible or currently ready to deploy in the near future which finally fully screened them out of our selection.

3.3.3 Vision Based Alternatives

Preceding signal alternatives, vision based alternatives were evaluated. Celestial navigation uses the night sky as a map to provide an accurate location. Clear skies, night time, low light pollution and bulky cameras are all required for celestial navigation to be a feasible option. The clearest visual navigation applications were found on maritime vessels that were able to carry the large amount of technology that is required. Celestial navigation was screened out for these reasons. Visual mapping, an alternative that compares the terrain features from a camera with referenced images is proving a feasible method of navigation. However, the tech relies heavily on high definition cameras and additional hardware that are currently unable to meet the SWaP requirements of the army's SUAS.

3.3.4 Combining the Alternatives

Finally, integration of these alternatives with GPS is expected. Therefore, the integration combinations were also evaluated. Three combinations were retained: GPS Augmented TIMU, TRE-G3TAJT, and GPS Augmented NAVSOP. The TIMU and NAVSOP alternative are viable options in the presence of GPS. TRE-G3TAJT is a new technology that is available as commercially off the shelf. It uses a processor that can channel the signal from all GNSS systems such as GLONASS or BeiDou. Furthermore, IMU's could be integrated into the multi-GNSS technology that would give any SUAS the ability to operate completely signal free as long as it was able to get some signal throughout the mission. This would further improve upon the security and redundancy of the navigation on the Puma or Raven. Finally, we considered a non-technological approach that would significantly reduce the cost of procurement of a new technology by simply changing doctrine. After considerable research into the technology and doctrine the team agreed that the solution to attacks on GPS navigation would have to be technological one.

Table 2: Feasibility Screening Matrix

Alternative	Factors with Threshold Values								Practical	Go/No-Go Status
	Time Period (Less than 10 Years)	Integrity Objectively: 0.999 Constructed: High	Accuracy 100 m 90% Confidence	Availability Objectively: 0.999 Constructed: High	Continuity Objectively: 0.999	Size	Power	Weight		
Intertial Alternatives										
INS/IMU	Go	Go	Go	Go	Go	Go	Go	Go	Go	Go
TIMU	Go	Go	Go	Go	Go	Go	Go	Go	Go	Go
Signal Alternatives										
eLoran	Go	Go	Go	Go	Go	Go	Go	Go	Go	Go
NAVSOP	Go	No-Go	Go	Go	Go	Go	Go	Go	Go	No-Go
Known Satellites	Go	Go	Go	Go	No-Go	No-Go	Go	No-Go	No-Go	No-Go
M-Code GPS	No-Go	Go	Go	Go	Go	Go	Go	Go	Go	No-Go
Pseudolites	Go	Go	Go	Go	Go	Go	Go	Go	Go	Go
Anti-Jam Antenna	Go	Go	Go	Go	Go	No-Go	Go	No-Go	No-Go	No-Go
Vision Based										
Celestial NAV	Go	Go	Go	No-Go	No-Go	No-Go	Go	No-Go	No-Go	No-Go
Visual Mapping (stand-alone)	Go	No-Go	Go	Go	Go	Go	No-Go	Go	No-Go	No-Go
Combination Alternatives										
TRE-G3TAJT	Go	Go	Go	Go	Go	Go	Go	Go	Go	Go
GPS Augmented IMU	Go	Go	Go	Go	Go	Go	Go	Go	Go	Go
Visual/IMU Augmented	Go	No-Go	Go	Go	Go	Go	No-Go	Go	Go	No-Go
GPS Augmented NAVSOP	Go	Go	Go	Go	Go	Go	Go	Go	Go	Go
Operational Changes	Go	No-Go	Go	Go	Go	Go	Go	Go	No-Go	No-Go

4. Decision Making

4.1 Value Scoring

The alternatives in Table 2 that passed feasibility screening were evaluated based on total value scores. Total value scores are a sum of value scores from individual value measures. Raw data from each alternative was passed through a value function for its corresponding value measure which produced a value score for that measure. Again the summation of the individual value scores for a particular alternative created the total value score with which alternatives were compared against one another.

Figure 4 is a qualitative representation of the quantitative model the team build to evaluate the alternatives. The node in the top tier is the fundamental need of the system or the client. The nodes in the second tier are functions and requirements of the system derived from the functional analysis the team conducted and from correspondence with the client. The team then analyzed what objectives the client intended to reach within each function or requirement, for example if the function is to launch the UAS, then the team knows that the alternative cannot weigh down the UAS to the extent that it cannot get

airborne. The results of this analysis are represented by the third tier. These objectives also begin to hint at how the team will be able to quantifiably measure each alternative. For example if the objective is to minimize the size of the alternative, then the team knows its unit of measure needs to be a size unit, such as mm^3 . This leads into the fourth tier of Figure 3 with are the value measure the team used to ensure that the client’s objective within each requirement or function was being met. This whole model was verified with the client before proceeding to a quantitative evaluation to ensure client satisfaction and more importantly, to ensure an understanding of the system so that the model would recommend selection of the best alternative for the given problem. Once the qualitative model could be used as a quantitative model, the team had to create value measures but before proceeding to describe how the weighted system was created, it is important to note that because some data was not publicly available and because there are no concrete, universal units of measure, constructed scales were used. Constructed scales were used for integrity, availability, and continuity.

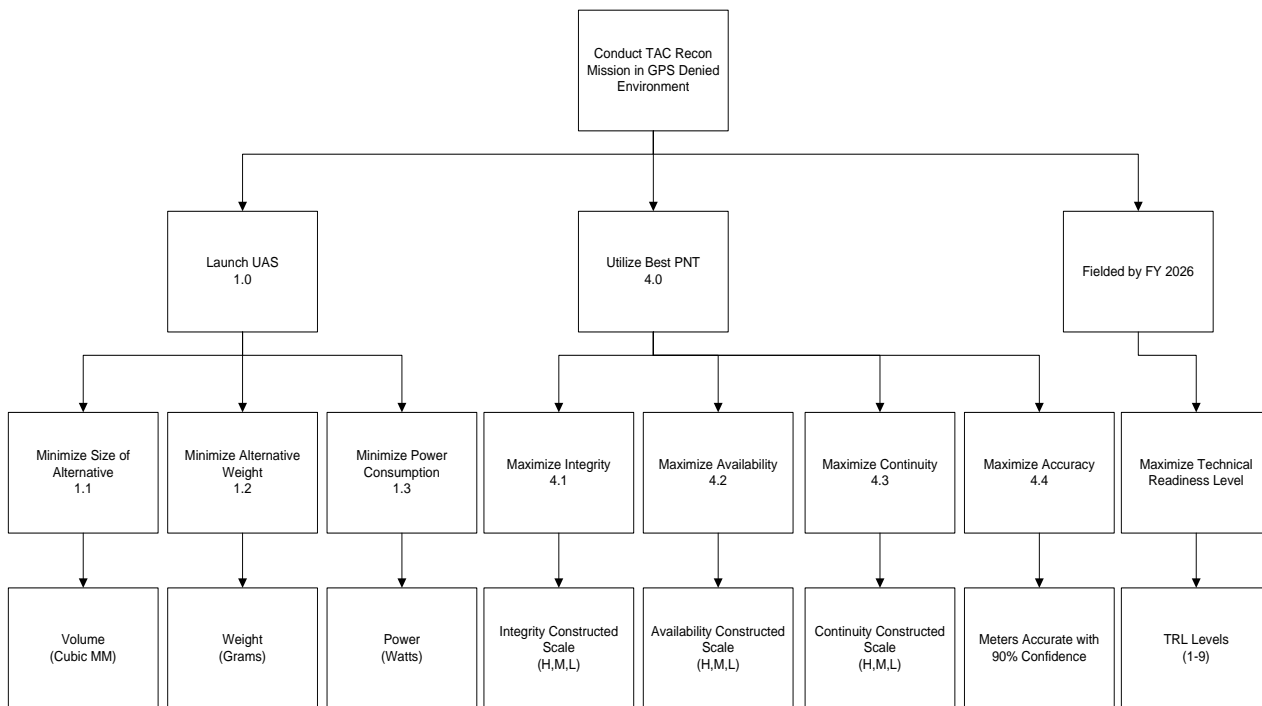

Figure 4: Qualitative Value Model

Once the value measures had been established, threshold and objective values had to be established to include how the client valued data that fell within that range. This is the creation of the value function which is used to assess the raw data of an alternative and assign the alternative a numeric score (0-10) used to represent how much value a particular quantity of that alternative generates for the alternative. Figure 5 is a representation of the value functions created for each value measure the team used to evaluate different alternatives with specific graphical examples of size and procurability. It can be seen that at this point in the process, raw data from each alternative can be fed into the appropriate value function and produce a score for its respective alternative in that category. Simply adding these preliminary value scores together would yield a total value score for a respective alternative, however, at this point in the process the score are all weighted equally in both importance and possible variability within each value function. Not including these two factors make the model a poor representation of the real world scenario; therefore, the team created a weight scale, a weight corresponding to individual value measures, which it could then multiply against the preliminary value scores. This process would help improve the model’s ability to accurately represent the real world situation.

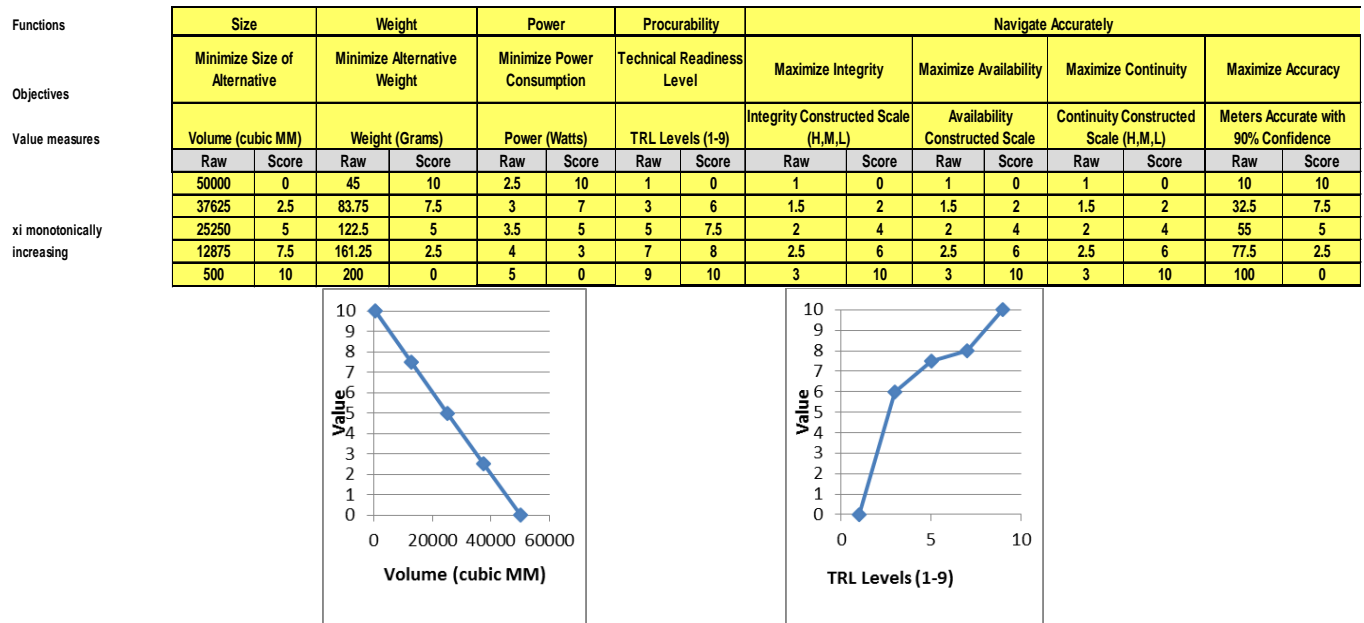

Figure 5: Value Models

Weights were created by arranging the value measures on a matrix as seen in Figure 5. The axis of the matrix are ‘Importance’ and ‘variability.’ Because each of the value measures represented different objectives, of different importance, the value measures could be separated into categories of ‘Mission Critical’ or high down to ‘Mission Enhancing’ or low importance. The value measures could then be separated along the other axis of variability. This variability is referring to the variability within the value measure and is also referred to as a capability gap. For example, when evaluating integrity of an alternative, it scored high in its importance to the client, and in respect to continuity. In respect to the capability gap alternatives integrity varied more often than their continuity; therefore, integrity made it into the top-left of the matrix earning it the most weight. The rest of the alternatives were evaluated this way, ensuring that weights were decreasing as they moved lower or more to the right of the top left. This is how the weight reflect importance and variability.

Highest Weight		Level of importance of the value measure					
		Mission Critical	Swt	Mission Effectiveness	Swt	Mission Enhancing	Swt
Capability gap (Variation)	Large	Maximize Integrity	100	Maximize Availability	60	Technical Readiness Level	30
	Medium	Maximize Continuity	80	Maximize Accuracy	50	Minimize Power Consumption	20
	Small		70	Minimize Size of Alternative	40	Weight (Grams)	10

Figure 6: Swing Weight Matrix

The weights were then summed and the individual weights then divided by the total to get a decimal weight that could be multiplied against the preliminary value scores to convert them to the final value scores of a particular value measure for a particular alternative. All of the decimal weights add to one, so that the multiplying does not increase the preliminary value score by a certain factor but rather reduces the score so that when they are combined to form the total value

score for a particular alternative that alternative cannot exceed a total score of ten; ten is what the ideal alternative would score.

Figure 6 is a stacked-bar chart representing the total value scores of each alternative. The alternating colors correspond to a specific value measure and their large size or lack thereof represent a high score within that value measure or a low score, respectively. The TRE-G3TAJT and the TIMU had very similar scores and were the highest scoring of the alternatives. This evaluation does not necessarily guarantee that both alternatives are equally recommended because cost has yet to be evaluated.

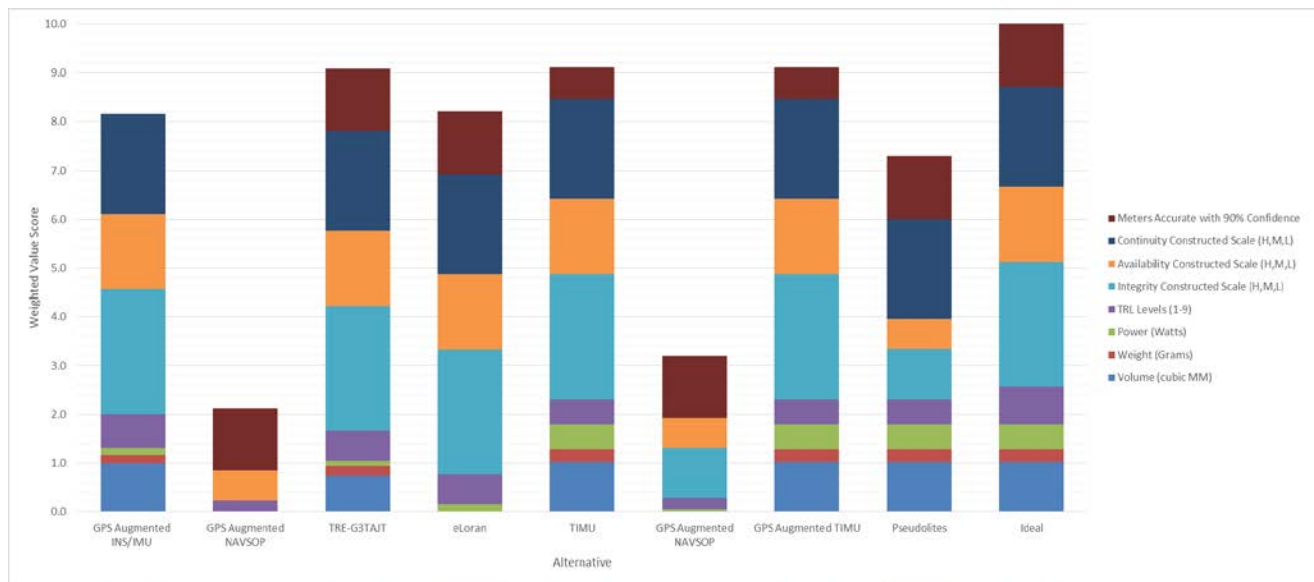

Figure 7: Weighted Scoring Results

4.2 Costing Considerations

Costing analysis presents many challenges. Many of the technologies researched were still in early developmental stages, and therefore little costing data was available. Some alternatives investigated were off the shelf requiring no supporting infrastructure, such as IMUs. However, other options investigated such as Pseudolites or M-Code GPS require significant infrastructure that exists separately from acquisition costs. In order to establish per unit costs, hard numbers for acquisition were developed while full infrastructure costs were marginally considered but not explicitly priced. Pricing was available for multiple systems from different commercial organizations, while alternatives like NAVSOP were estimated based on likely components of the system. A basic COCOMO evaluation was applied for estimating the software costs per unit (Merlo, 2002). To conclude the costing analysis, the costs were compared to the relative value score of the system. Based upon stakeholder requirements, a cost constraint of \$5000 was put in place. Based upon this constraint the most prominent alternative TRE-G3TAJT would be eliminated. However, the alternative is retained as the highest valued alternative based upon its emerging capabilities and likely reduction in price based upon future production. To estimate this possible decrease in cost for a multi-GNSS receiver a cost estimation similar to the estimation for NAVSOP was completed. The full costing breakdown for the alternatives are discussed in the following sub-sections.

4.2.1 Initial Costing

To begin the costing, all alternatives that are available COTS and had an associated cost were organized in to the following table and the source in which the cost came from was annotated in the source column. If the cost was not readily available for the alternative the source was annotated as estimated. The estimation process will be discussed in further detail in the following sub-sections.

Table 3: Initial Costing

Alternative	Cost (Per Unit)	Source
GPS Augmented INS/IMU	\$3,000.00	Jack Mawson, SBG Systems
GPS Augmented NAVSOP	\$1,067.27	Estimated
TRE-G3TAJT	\$9,700.00	Javad GNSS LLC
eLoran	\$4,419.23	MSS Defense
GPS Augmented TIMU	\$6,750.00	Estimated
Pseudolites (ground)	\$7,500.00	Locata
Pseudolites (air)	\$11,250.00	Locata

After the initial costing was completed, the values obtained were plotted against the alternative associated value score. The plot, shown in Figure 5, demonstrates the value to cost comparison. Alternatives that score the highest and cost the least are considered to have the highest value to cost. In this initial costing phase, notice that the multi-GNSS alternative scores high, but is one of the most expensive alternatives. Moreover, the off the shelf price for that specific receiver resides outside the costing constraints outlined by PM-UAS. When looking at this costing landscape, the team raised multiple questions surrounding the technology that enables multi-GNSS. Discovery of many off the shelf products like GPS/Glonass watches, and other devices prompted the question to further analyze the specific component costs associated with producing a multi-GNSS receiver. The entire breakdown of this analysis is included in the next sub-section.

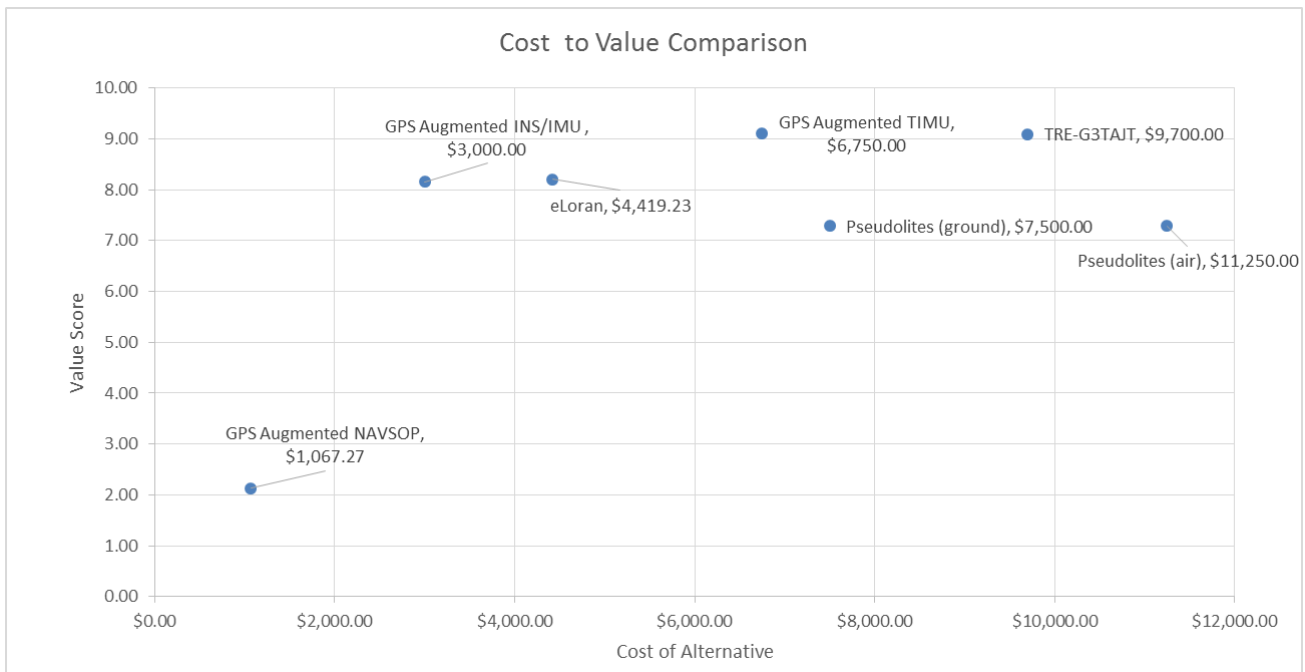

Figure 8: Cost to Value Comparison

4.2.2 Estimating Multi-GNSS Costing

After the discovery of similar technology having significantly reduced cost to the off the shelf product provided by Javadd Inc, research began into the components that enable multi-GNSS. Multiple companies that provide analogous technology were contacted for requests for information. These companies include Javadd, Linx, and Trimble. After aggregating data from them for their multi-GNSS enabling chips, a components search began to create a semi-comprehensive list of components that are used in a complete GPS like receiver. The solution can be considered a home-brew solution that

would likely produce functionality that is similar to the desired outcome and provides a benchmark for costing for future analysis of the alternative.

Included in table x is the developed component list and associated costs. Important considerations for this component list is that the chosen multi-GNSS module receives three satellite navigation systems however, it is capable of receiving signals across the entire bandwidth used for GLONASS, BeiDou, GPS, and Galileo. Secondly, the processing computer is an off the shelf Raspberry Pi computer that is not an industry standard for navigation systems, but has grown in popularity for small, inexpensive computing solutions. Finally, the GNSS Antenna included in the costing is a maritime size antenna that currently wouldn't meet the SWaP requirements, however was chosen as a proof of concept antenna.

Table 4: Components Costing

Components Lists	Component Cost	Source
GPS/GLONASS/QZSS Receiver Module	\$ 18.17	Linx
(PTH) 2"x1.34" 250hole Epoxy Fiber Pitch 0.1" (Veroboard)	\$ 12.90	Veroboard
Raspberry Pi Model B 512MB RAM	\$ 39.95	Raspberry Pi
JTAG (2x10 2.54mm) to SWD (2x5 1.27mm) Cable Adapter Board	\$ 4.95	JTAG
Leica AS10 Multi Band GNSS Antenna	\$ 1,600.00	Leica
TCVCXO Oscillators 26MHz 3.3V 0.1ppm 0-	\$ 15.40	Pletronics
Power Management IC Development Tools Grove - Voltage Divider	\$ 5.90	Seed
Controller Software- Programmed into Raspberry Pi control processor	\$ 7.59	Estimated

To complete the component costing analysis, an estimation for the controlling software was completed using a basic COCOMO model (Merlo, 2002). This constructive cost model uses an algorithmic software cost estimation model applying basic regression with parameters derived from estimated project data. Using this model, an assumption was made that the software development would be organic to the organization developing the alternative. Additionally, an estimate of 42,432 lines of code would be developed over 15.5 man months. The entire breakdown is found in table 4 which estimates the software costs to be \$75,884.00 or \$7.59 per unit across 10,000 units.

Table 5: Software Estimation

Effort:	122.83
Duration (Man Months)	15.55
Lines of Code	42432
8 hour work day	
20 days per month	
Average Programmer (per Hour)	30.5
Total Hours Per Month	160
Total Hours for Project	2488
Cost For Programming	\$ 75,884.00
Total Units	10000
Price Per Unit	\$ 7.59

In addition to the components estimation, estimation for research and development budget, overhead, and testing were made to give an expected cost for fielding the device with a small design and development team. These costs were estimated based on interviews with professors at the United States Military Academy with experience in product development. One such interview was conducted with Dr. Vikram Mittal, who formerly worked for Draper Labs. These assumptions were aggregated into table 5 and an estimation for developing and producing 10,000 units was created to derive an estimated per unit cost of \$1,861.36.

Table 6: Complete Cost for Multi-GNSS

Complete Cost Analysis	
Number of Units Produced	10000
Research and Development Budget (Including Personnel)	\$ 1,300,000.00
Overhead	\$ 65,000.00
Testing (6 Month Testing)	\$ 200,000.00
Material Cost (Based on 10,000 Units)	\$ 17,048,584.00
Total Estimated Cost Per Unit	\$ 1,861.36

4.2.3 Updated Cost to Value

After completing a full estimation of cost for an in-house built multi-GNSS receiver, the cost to value comparison is done again. With the estimated \$1,861.36 cost for a multi-GNSS system, the alternative technology now becomes the dominating alternative giving the greatest value for the least cost. Shown in figure x is the updated cost to value comparison. Notice the position of the TRE-G3TAJT alternative now dominating the remaining alternatives based on its cost to value plot.

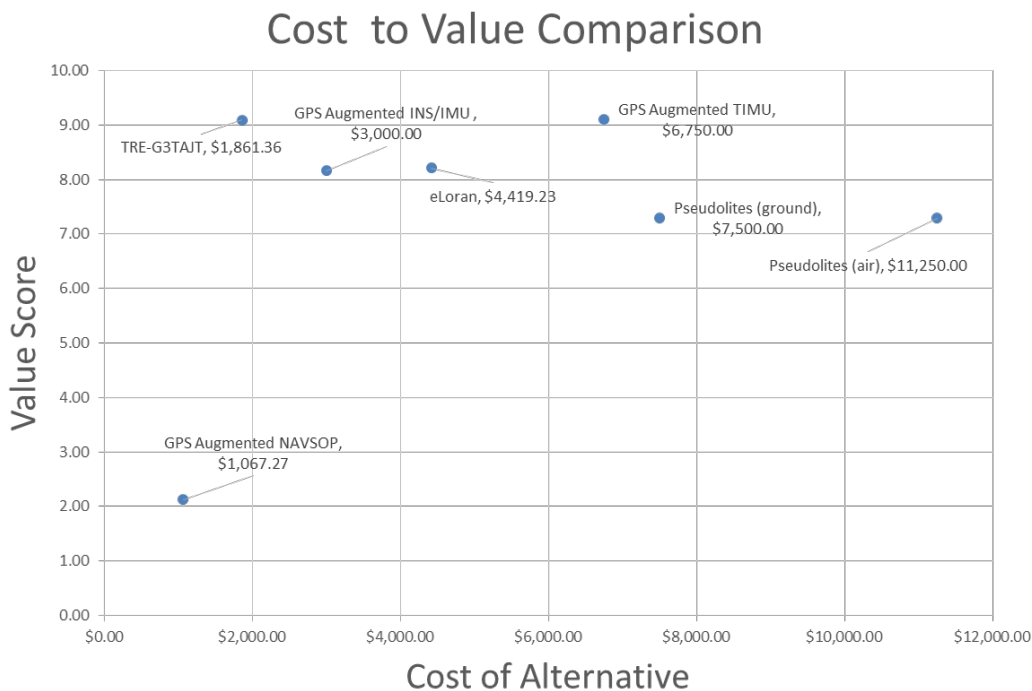

Figure 9: Updated Cost to Value

4.3 Sensitivity Analysis

In order to complete the analysis of alternatives, sensitivity analysis of the prioritized weights was completed. The resulting analysis concludes that multiple of the value scores for each alternative are highly sensitive to the prioritized weights. What this means, is that the recommended technology can be subject to the stakeholder preferences and priorities. With changes in the importance on factors like weight, power, or accuracy the recommended alternative may change dependent on how the stakeholder assesses their importance. Shown below are the three most sensitive factors that may affect the recommendation. Provided are short discussions on the analysis for each of these sensitive factors. However, the important take away from sensitivity analysis is the importance of comprehensive stakeholder analysis. In all future work, the design teams should take a very specific focus in ensuring the evaluation criteria are accurately weighted according to the stakeholder’s priorities. By ensuring the evaluation criteria perfectly matches the stakeholder’s priorities, the recommendation will answer the stakeholder’s need.

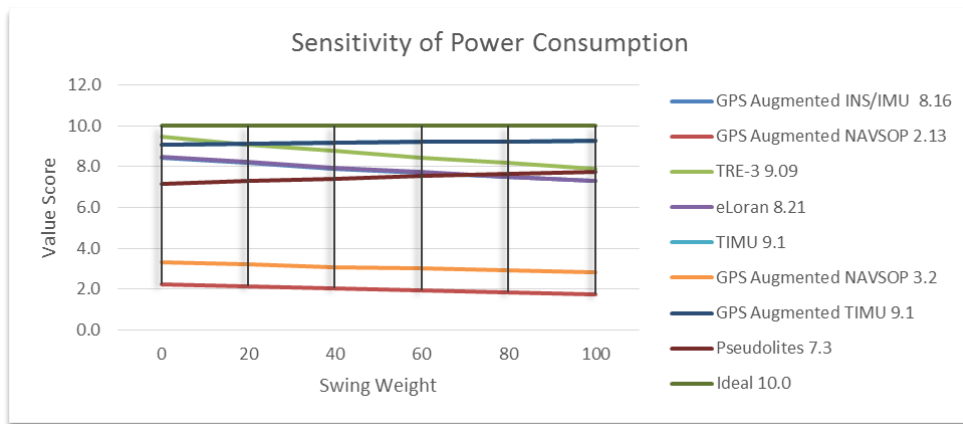

Figure 10: Sensitivity of Result to Power Swing Weight

Shown in 10 is the sensitivity analysis of the power consumption criteria. Each line depicts a different alternative with the varying degree of importance (weights) across the horizontal axis and their overall value score on the vertical axis. The recommendation in this report is based on the power criteria having a swing weight of 20. However, as the swing weight of power varies, the graphic depicts an intersection of the TRE-G3TAJT alternative and the GPS augmented TIMU with the TIMU becoming a more valued alternative with swing weights higher than 20. This is important to note because a slight change in prioritization of power consumption can affect the overall weighted score of the alternative which may completely change the recommendation. However, the TRE-G3TAJT remains competitive across all swing weights, and the TIMU is a risky proposition at best.

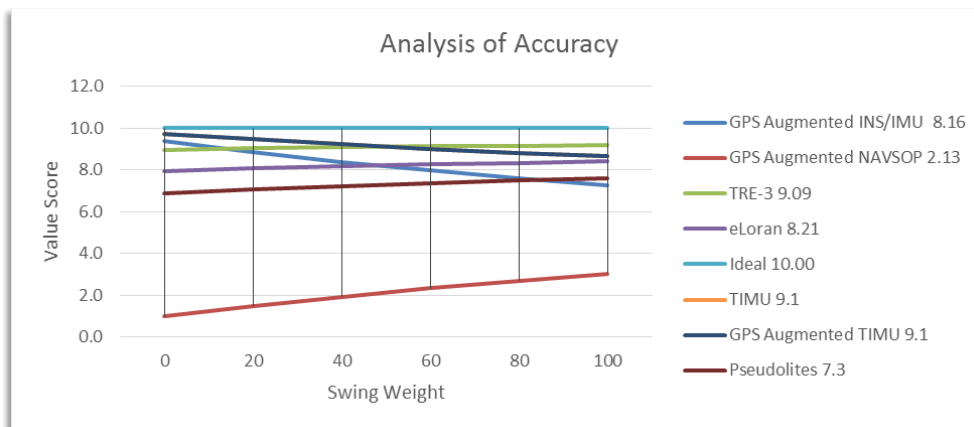

Figure 11: Sensitivity Analysis of Value to Accuracy Swing Weight

The sensitivity analysis of accuracy is shown in Figure 11. The chart shows all alternative solutions with the varying weights on the horizontal axis and the overall value score on the vertical axis. The recommendation in this report is based on the accuracy criteria having a swing weight of 50. Once again the GPS augmented TIMU crosses with the TRE-G3TAJT as well as the GPS augmented IMU at the low priority end. However, the TRE-G3TAJT remains competitive across the top of the chart no matter the swing weight.

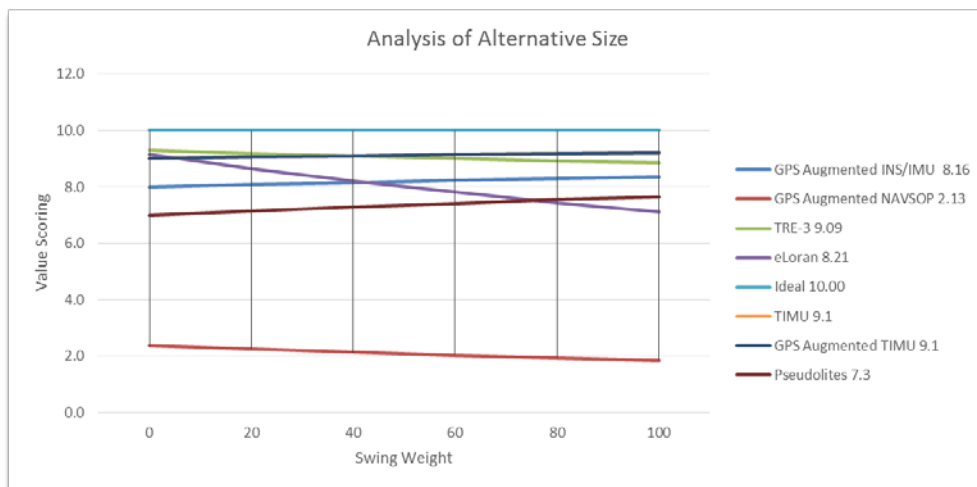

Figure 12: Sensitivity Analysis of Value to Size Swing Weight

Figure 12 displays the sensitivity of the alternatives to changes in size. As in the previous two cases, TRE-G3TAJT is beaten by GPS augmented TIMU for some swing weights. However, similarly to before the Multi-GNSS option is competitive across the board and carries far less inherent risk than the unproven TIMU.

4.4 Risk

Despite the extensive research, countless requests for information, and making the best estimates an undergraduate team could make, there is still some risk of uncertainty in the aforementioned analysis. For example, due to the lack of a universal unit of measure or the lack of this information being publicly available for value measures such as integrity, availability, or continuity, the team had to develop and measure alternatives on constructed scales. Within this type of evaluation there is inherent risk that how the team scored a particular alternative within this constructed scale may be

incorrect. It may also be that the constructed scales do not accurately reflect the variability of values representative of the alternatives. This means that values of high, medium, and low may be too simple. This is not to say that the team did not understand the definition of these terms or value measures and that they did not score the alternative to the best of their ability. On the contrary, the team spoke extensively with experts to ensure no misunderstanding about these evaluations and to ensure that the evaluations were not overtly incorrect.

Another source of risk within this analysis and recommendation is an assumption the team made on the readiness of the TIMU. Due to the lack of information on this alternative published since 2013, with the exception of a single article published in 2015, which did not offer any new or developmental insight, the team assumed that the alternative was no longer being developed. Thus, although the Multi-GNS receiver, TRE-G3GAJT and the TIMU received similar total value scores, the team elected to recommend Multi-GNS as a solution. There is risk in this assumption because it is possible that the TIMU has made significant advancements and that the information used to evaluate it was outdated because new developments are being kept secret; however, the team made the best evaluations it could with the information it could gather so as to provide the best and most reliable alternative to its client.

5. Conclusion & Future Work

5.1 Recommended Alternative

The analysis completed for PM-UAS recommends the TRE-G3TAJT by JAVAD GNSS Inc. The alternative is a commercially off the shelf receiver that is capable of receiving emissions from the NAVSTAR, GLONASS, Galileo, and BeiDou GNSS. The off the shelf alternative does currently break the cost constraint outlined by the client. However, analysis suggests the production cost will lower as the emerging technology grows in scale and is built in house. With the availability of interfacing documents, field programmable gate arrays, which are the crux of the technology, can now be coded to receiving the PNT data from all of these constellations. This enables producers to build reliable receivers capable of interfacing with all constellations as well as augmentation systems. Because of this capability, multi-GNSS is considered the best option to integrate in to the Army’s small unmanned aircraft systems as it provides redundant access to PNT sources in the event the vehicle navigates in to airspace in which NAVSTAR capabilities are degraded. As shown in Figure 12 there is multiple areas of overlap, and standalone allocations of the frequency bands demonstrating the redundancy and robustness of multi-GNSS. With these allocations of frequencies, good lock on multiple constellations can put significantly more satellites in the field of view, increasing the precision of the PNT calculations. Moreover, the allocation schema creates an environment where availability of one constellation at any given time is much higher, even if GPS is being degraded.

In addition to the redundancy of signal availability multi-GNSS increases the viability of other alternatives like small IMU’s. Because the open source code used in these constellations can be used for error correction, the IMU’s feasible for SUAS are able to be error corrected more frequently, making their drift rates more acceptable. This continues to build a strong case for emplacing multi-GNSS capability in to reconnaissance driven SUAS.

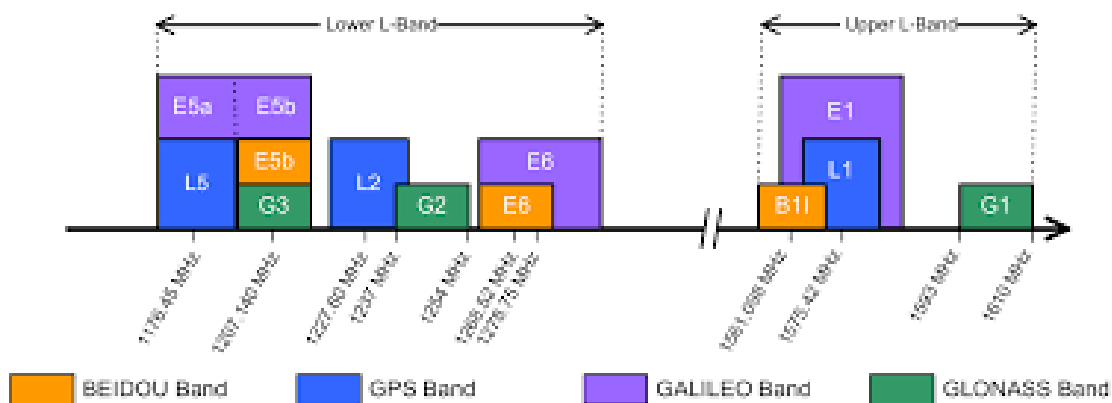

Figure 13: Multi-GNSS Frequency Bands

5.2 Future Analysis

Future work should include additional analysis and development into inertial measurement alternatives as well as low frequency emission alternatives such as eLoran. Research into both of these fields provides insights into alternatives that operate completely independent of all GPS like emissions. IMU/INS should be further considered for further analysis for those that desire completely organic navigation systems that do not rely on any system external signals. eLoran and low frequency emissions should be considered for signals based navigation that operate completely separate of the frequency bands used for GPS like emissions.

In addition to continued analysis in to alternatives, the team suggest research be conducted in the ability to create military level security, for open source use of multi-GNSS systems. Enabled by fast processing speed, receivers should be capable of maintaining multiple satellite locks. This creates the opportunity to encrypt the sequence of PNT data received and used for navigation. Additionally, exploration into multi methods of signal validation should be explored using larger platforms like Gray Eagle. Using multiple methods to validate the open source code, provides the opportunity to enable SUAS as CAT-1 targeting platform.

6. References

- Adams, T. (2000). 10 GPS Vulnerabilities. *C4I- Computer Security and Intelligence*.
- Anonymous. (2014, January). Pseudolites. Retrieved from <https://www.pdpnt.army.mil/products/products-in-development/>
- Anonymous. (n.d.). JAVAD GNSS. Retrieved from <http://www.javad.com/jgnss/index.html>
- Arun, S. US Army successfully tests electronic jamming capability for Gray Eagle UAS. *Janes Defence Weekly*, 2014-08-04.
- Basker, S. (2007, October). Enhanced Loran (eLoran) Definition Document. Retrieved from [http://www.loran.org/ILAArchive/eLoran Definition Document/eLoran Definition Document-1.0.pdf](http://www.loran.org/ILAArchive/eLoran%20Definition%20Document/eLoran%20Definition%20Document-1.0.pdf)
- Dunnigan, J. (2013, November). A Solution For The GPS Jammer Threat. Retrieved from <https://www.strategypage.com/dls/articles/A-Solution-For-The-GPS-Jammer-Threat-11-21-2013.asp>
- Kenan Institute (n.d.). GPS - Introduction to GPS.
- Merlo, N. (2002). COCOMO Constructive Cost Model. Retrieved from https://files.ifi.uzh.ch/terg/arvo/courses/seminar_ws02/reports/Seminar_4.pdf
- Oktay, H. (2011, March). Airborne Pseudolites in a Global Position System Degraded Environment. Retrieved from <http://www.dtic.mil/dtic/tr/fulltext/u2/a540070.pdf>
- Parnell, G., Driscoll, P., and Henderson, D. (2008). *Decision Making in Systems Engineering and Management* (2nd ed.). Hoboken, NJ: John Wiley & Sons.
- Schmidt, G. T. (2015). Navigation Sensors And Systems In GNSS Degraded And Denied Environments. *Chinese Journal Of Aeronautics* 28: 1-10.
- Wasserbly, D. (2014). AUVSI 2014: US Army nearing updated Gray Eagle, Shadow UAS. *Janes Defence Weekly*, 2014-05-14.
- Won, D. et al. (2015). Performance Improvement Of Inertial Navigation System By Using Magnetometer With Vehicle Dynamic Constraints. *Journal Of Sensors* 1-11.
- Zhou, J., Nie, X., and Lin, J. (2014). A novel laser Doppler velocimeter and its integrated navigation system with strap down inertial navigation. *Optics and Laser Technology* 64: 319.