

Implementation of Systems Engineering Approach in Academic Projects: Software Defined Radio Technology Development as a Case Study

Ali Saboonchi and Guangming Chen

Department of Industrial and Systems Engineering
Morgan State University, Baltimore, MD, USA

Corresponding author's Email: guangming.chen@morgan.edu

Abstract: Each year, federal and private agencies spend billions of dollars on research projects that academic institutions conduct for them. However, the communication language between these agencies as clients and academia as hosts, is not very efficient and well-established. This has resulted in lack of clarity in clients' description of what exactly to be expected and in hosts' description of their capabilities and challenges. In addition, many of these projects are essentially interdisciplinary and demand the involvement of diverse research teams from different university departments. Lack of cohesive collaboration among these diverse teams results in mismatches between different compartments of project output, and consequently, generation of superfluous product prototypes. Finally, for their real-time tracking and later retrieval, the current situation of documentation of academic projects needs to be significantly altered. We suggest that the presence of a systems engineering team should be an indispensable part of a large academic research project, in order to monitor and manage the various aspects and phases from initiation to completion.

For this purpose, we proposed a systems engineering model specific for academic research projects, which considers both strengths and challenges of universities as host research institutes. As a case study, we applied this proposed systems engineering approach on a NASA-funded project at Morgan State University (MSU) which was about design and implementation of software defined radio (SDR) for space exploration. Application of this model significantly improved the professional dialogue and technical clarifications between NASA and MSU partners, as well as within MSU teams. Moreover, the sub-system compatibility among different modules of the implemented product was notably enhanced. Overall, application of systems engineering approach in academic projects can result in mutual benefits for the institution and either federal or private client.

1. Introduction

Contemporary product design and manufacturing, from small electronic chips to large spacecraft, involve numerous components and require a diverse set of approaches. Some project failures are due to lack of compatibility with user requirements, and not meeting deadline or budget limits. Time, money and the ability to deliver the appropriate product are all significant factors for clients. In many cases, products are delivered to the clients with delay because of design problems and incompatibilities with client's requirements. How can a project overcome these obstacles, especially when multiple teams contribute to the different modules? Systems Engineering provides the answer to this question (Ave-Klutse Kodzo Paaku Kludze, 2003).

Academic institutions regularly receive research funds from federal agencies and private industries in order to accomplish their proposed projects. Federal investment on academic research significantly increased from the time of World War II to the present time. According to a National Science Foundation (NSF) survey (Matthews, 2012), the United States federal government spent \$40 billion for research and development (R&D) in 900 universities in fiscal year 2011. This means that the government covered 62% of \$65 billion academic R&D in that year. Noteworthy to mention, 20% of these federal grants went to the nation's top ten most-funded universities (Matthews, 2012). Also, majority of this budget was allocated to large (> \$1 million) grants.

This federal support is related to the fact that universities have been recognized as innovative and creative research centers that are able to attract talented human resources and come up with non-traditional answers to new questions and to promote economic growth and national advancement. According to a study, 80% of pioneering industries were developed from the research findings in universities (Matthews, 2012). However, academic projects encounter their own challenges and limitations that are unique to academic environments and make them different from those large and well-established companies.

First of all, most projects that are proposed to universities are novel and quite challenging and are not expected to have traditional answers. Although universities have brilliant fresh-thinking researchers and scientists in their laboratories, it is not

guaranteed that they can come up with right outputs in predefined time frame. In this sense, universities and academic research institutes are different from large companies that have decade-long experience of tackling traditional problems within a well-defined deadline.

Secondly, there are many departments, centers, and laboratories within a university which, in contrast to large companies, are not managed by a hierarchically structured, top-down command system. Instead, these research groups are independent and less communicable with each other. For instance, laboratories may not be aware of ongoing research and the extent of research and experimental facilities in other laboratories even within the same department. In other words, many university laboratories are like small businesses without even loose connections with one other, are under almost no hierarchy, and often survive either by small grants or university funds. Therefore, when a large interdisciplinary project is funded in a university, it takes extra time and energy to gradually shape a new collaborative environment among relevant centers and laboratories. The situation is very different in large companies which have a well-established organizational structure.

Thirdly, the limited number of human resources is a critical aspect of large projects performed in academia. Also, the workforce devoted to academic project primarily consists of graduate students. Although these young researchers may come up with creative solutions to challenging parts of a project, they have their own limitations. Depending on whether they are masters or doctoral students, they have their own coursework duties that will take a large portion of their worktime. They also need time to acquire the prerequisite training necessary for conducting research on the project. Moreover, their graduate study years are usually short and cannot be compared with the well-trained full-time employees who have continued their positions for many years.

Finally, the technological and experimental facilities of universities and small research institutions are usually limited. Because of this, efforts are primarily devoted to creative designs and preliminary implementations. In other words, projects often involve generation of early prototypes with short-term validation and tests and do not commonly involve commercialization and long-term validations. These limitations in facilities are especially critical and present in early negotiations, altering expectations and objectives as set by client agencies as well as constraints and requirements by host universities. As such, academic projects usually end up as modified or simplified versions of the original objectives by the clients.

Application of a systems engineering approach dedicated for academic projects may address all of the above-mentioned limitations and challenges. However, traditional systems engineering handbooks, such as the National Aeronautics and Space Administration (NASA) Systems Engineering Handbook and International Council on Systems Engineering (INCOSE) Systems Engineering Handbook (INCOSE, 2010) are too complicated and detailed to be used in small research institutes and universities, and especially to be used by researchers with no systems engineering training. These are mainly written for large federal organizations, such as NASA, DoD, and large well-established companies, and they also include final implementation phases that are barely performed in academia. As mentioned, universities mainly focus on building prototype models and this is at most half of the lifecycle of a given product. Therefore, a revised systems engineering model should be provided for academic projects.

The goal of this research is to introduce and develop a systems engineering protocol and process specific for universities or small research institutes who have no systems engineering background and are interested in performing their projects in a systematic manner. Our presented model is simple and easy to follow by a committee selected from each participating team, and focuses mainly on necessary requirements of academic research centers. As a case study for implementation of this new model, we used the software defined radio (SDR) technology development project. The SDR project is an interdisciplinary NASA-funded project for space exploration performed by several research laboratories mostly located in the Electrical Engineering Department at MSU.

We aimed to investigate into what extent application of this model improves the professional dialogue and technical clarifications between NASA and MSU partners, as well as within the MSU teams. Usage of CORE software is helpful in developing context diagrams, and drawing systems requirements and documentations (Vitech, 2014). Moreover, we examined whether the sub-system compatibility among different modules of the implemented products was notably increased. Overall, application of systems engineering approaches in academic projects are observed to result in mutual benefits for both clients of federal or private and the host institution.

Section 2 will introduce the proposed systems engineering model for academic projects, and compares that with well-established methods for systems engineering in large organizations as described in the NASA Systems Engineering Handbook (NASA, 2007). Section 3 elaborately provides background for the SDR project that is considered as a case study for the proposed systems engineering model. It will also demonstrate the main resulting systems engineering diagrams for the SDR project. Section 4 summarizes the general improvements that application of the proposed system engineering method provided for the SDR project. Finally, concluding remarks and future development for this novel research topic are discussed in Section 5.

2. Academia Systems Engineering (ASE) Framework

In this section, we propose a systems engineering approach appropriate for academic projects, which is denoted as Academia Systems Engineering (ASE) framework. First, we introduce the general setting for involvement of a systems engineering team in a project. Then the ASE framework will be presented in details and compared with NASA's systems engineering process.

2.1 Systems Engineering in a Project Setting

Research shows that user engagement with the project from beginning to the end can better ensure that deliverables match the stakeholder's expectation and it is crucial for success (Kasser & Hitchins, 2011). It is not possible to come up with a clear objective and appropriate concept of operations (ConOps) unless the project team members and stakeholders build a strong relationship with one another. Also, determination of requirements has been recognized as one of the most difficult activities in systems development (Damian, 2007). This is due to the fact that it involves gathering and modeling information that validates the functionality by the system analysts and various stakeholders. The proper way of building this relationship with stakeholders, would be achievable by a knowledgeable systems engineering team. This paper proposes a simple and step-by-step systems engineering model for small organizations to complete projects in a more efficient manner and to present and report the project at sufficient systems engineering standards.

The system engineering discipline insists that robust communication between stakeholders and team members are necessary. Besides formal meetings, informal communication between project team members and marked stakeholders should be available. Important reasons and factors have been suggested for having such a strong relationship project teams and stakeholders (Damian, 2007). First, project team members should define a clear organizational structure with communicating responsibilities with corresponding stakeholder teams (Kasser & Hitchins, 2011). Indeed, stakeholder leaders may not have enough knowledge about project details; therefore, they should assign skilled team members who can be efficiently involved in system requirement definition. Second, establishing a peer-to-peer connection at all management, project, and team levels across project sites is essential. This will increase the effectiveness of requirement acquisition and validation for both sides.

Figure 1 shows our proposed schematic interaction among stakeholders, systems engineering team, and project's technical teams. As it is shown in this figure, the systems engineering team not only universalizes the language between individual project teams but also shapes a direct dialogue between these teams and corresponding agents in stakeholder side.

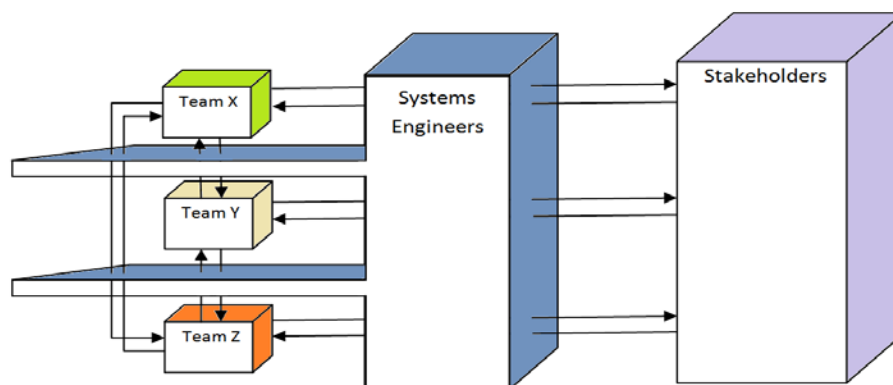

Figure 1. Schematic of Systems Engineering in a Project Setting

2.2 Academia Systems Engineering (ASE)

Academia Systems Engineering (ASE) Framework may be an appropriate systems engineering method for small institutes specifically targeted for university research centers. This new modified structure can enable research centers to incorporate systems engineering within their projects. Those with no systems engineering background will be able to follow this concise framework and accomplish their projects in a more efficient manner. In research and development projects, coming up with strong project requirements is an indispensable key to project success (Pohl, 2013). Three organizations most well-known on offering best techniques for writing vigorous requirements are NASA, INCOSE, and IEEE. The proposed method utilizes the NASA systems engineering method as a base model, with respect to which various comparisons are made. Systems

engineering, in its broad and historic roots, deals with a variety of topics, while the academic environment does not need to be involved with all of them. In this paper, our focus is on introducing necessary knowledge and techniques to academic research environment for improving technical development procedure of projects. For instance, the NASA project life-cycle process flow consists of seven phases. By contrast, our model focuses only on the first four stages of the project life-cycle: 1) Concept Study, 2) Concept and Technical Development, 3) Preliminary Design and Technology Composition, and 4) Final Design and Fabrication.

2.2.1 ASE Project Life Cycle

Most real-world projects consist of two main stages: (a) acquisition; (b) utilization. Since most projects performed in academia are only required to make a prototype, the ASE method will only focus on the acquisition stage which it breaks into four phases. Listing of these phases is as follows, and details are already explained in the System Design and Implementation Process Section.

Pre Phase A Concept Studies (Equivalent to Pre-phase A of NASA)

Phase A Concept Development and Project Formulation (Equivalent to phase A of NASA)

Phase B/C Design, Technology Completion and Fabrication (Equivalent to phases B & C of NASA)

Phase D System Assembly, Integration and Test (Equivalent to phases D)

Also, handling large number of demanding meeting reviews is beyond the power of academic research centers. The proposed ASE method selects only some of NASA’s critical meeting reviews and further modifies them. These meeting reviews will stand as formal Critical Meeting Reviews between project team members and stakeholders. The chosen meeting reviews are as follows:

- A. Mission Conceptual Review (MCR)
- B. System Requirements Review (SRR)
- C. Preliminary Design Review (Peer Review/ PDR)
- D. Critical Design Review (CDR)
- E. System Integration Review (SIR)
- F. Operational Readiness Review (ORR)

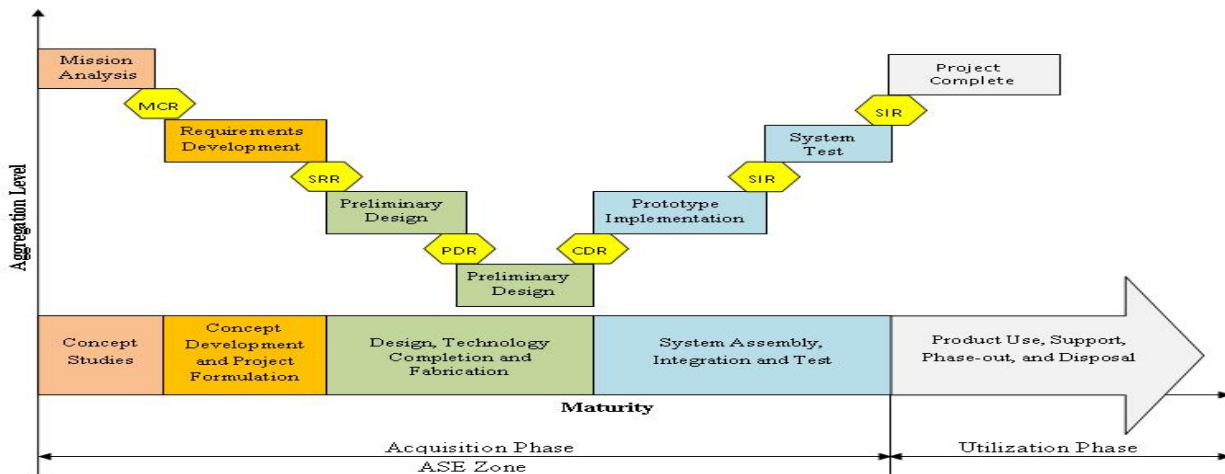

Figure 2. ASE Project Life Cycle

2.2.2 ASE System Design and Implementation Process

The ASE method for efficient interrelationships among system design and implementation processes is introduced as follows. In this approach, we involve the stakeholders through entire system design and the implementation process by shaping joint critical meeting reviews at different phases of project life. Also, we propose that technical team members should have a technical point of contact on the stakeholder’s side to have informal communication beside those critical meeting reviews.

The project starts with the stakeholder’s approval, entering pre-phase A Concept Studies. In this phase, academia team members would propose their mission objectives and constrains, as well as mission success criteria to the stakeholders. Following agreement between stakeholders and academic team members, and securing approval from the Mission Conceptual Review (MCR) meeting, the project enters the next phase. Also, a draft of system-level requirements needs to be made at this stage, and the needs of potential technologies are to be identified and specifically outlined.

The second phase of the project is Concept Development and Project Formulation. High-level requirements should be concreted. After finalizing the mission concept, it would be time for completing system-level requirements. High-level concept of operations (ConOps) should be generated, as well as a first attempt towards a context diagram. Beside these, the preliminary product breakdown and work breakdown structures should be drawn. Passing System Requirements Review is the key to the next phase.

Phase B/C corresponds to separate phases B and C of the NASA life-cycle process flow. In particular, this is the Design, Technology Completion and Fabrication phase, details of all functional and decomposition components of the system will be established. Following approval from Preliminary Design Review (PDR), next focus is on completing the design loop process. In the design loop, the four main parts need to be covered: 1) ConOps; 2) design and breakdown structure; 3) allocation of the various requirements such as functional, performance, and interface; and finally, 4) verification and validation plans for the system. Anything related to the design of the system such as fabricating hardware, software, and even reliability and quality control of system and subsystems should be performed in this phase. With approval from Critical Design Review (CDR), the project can move to the next phase.

Phase D, namely System Assembly, Integration and Test, constitutes the last phase of academic projects. System Integration Review (SIR) guarantees that the system in all levels of segments, components, and subsystems is available and ready for integration. In this phase, prototype fabrication should pass the various tests towards different system levels. Furthermore, system qualification and verification should also be applied. Final validations and system tests should be accomplished before Operational Readiness Review (ORR) which is the last meeting review. Securing approval from this meeting, indicates that the project is finished.

The proposed ASE model interrelationship among the system design processes is illustrated below.

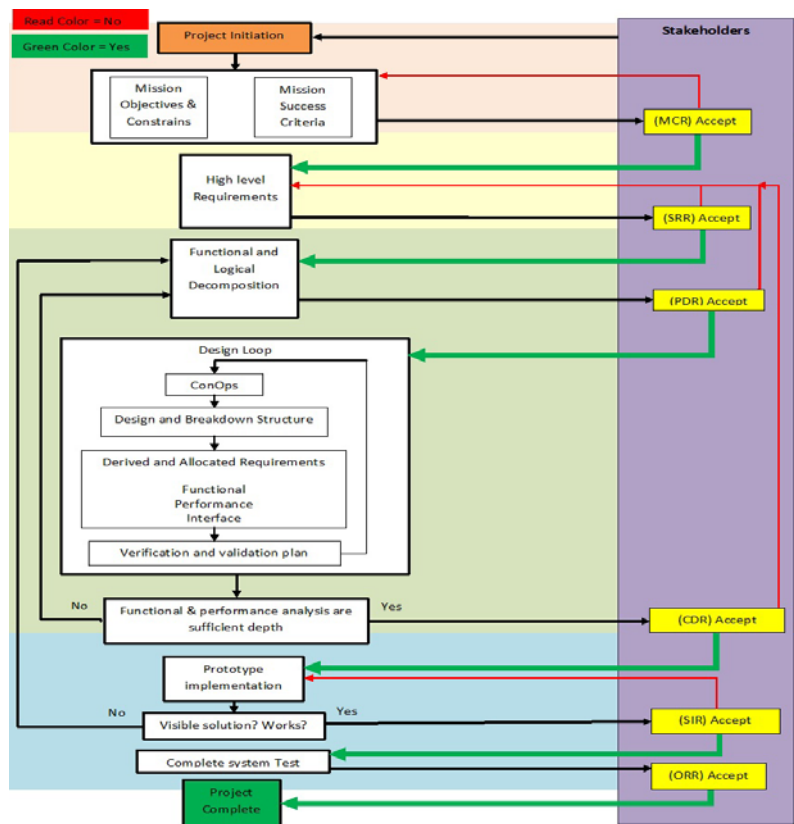

Figure 3. The Proposed System Design and Implementation Process

2.2.4 ASE Meeting Review Structure

The details of ASE project phases are given in the following table (Table 1).

Table 1. ASE Project Phases with Details

Phase		Purpose	Typical Output
Formulation	Pre- A Concept Studies	<ul style="list-style-type: none"> ● Allocate the mission objectives and constrains ● define mission success criteria ● MCR (Date) <p>To produce a broad spectrum of ideas and alternatives for missions from which new programs/projects can be selected. Determine feasibility of desired system, develop mission concepts, draft system-level requirements, and identify potential technology needs. Conceptual idea/s of mission success criteria.</p>	Feasible system concepts in the form of simulations, analysis, study reports, models, and mockups
	A Concept Development and Project Formulation	<ul style="list-style-type: none"> ● Concept of Operation ● Context Diagram ● Configuration of Subsystems ● Product Breakdown Structure (PBS) & Work Breakdown Structure (WBS) ● Technology Development ● Requirement Internals and Peer Reviews ● SRR (Date) ● Key Decision Point (Date) to conclude Phase A <p>To determine the feasibility and desirability of a suggested new system and establish an initial baseline compatibility with project mission. Develop final mission concept, system-level requirements, and needed system structure technology developments Define the project in enough detail to establish an initial baseline capable of meeting mission needs. Develop system structure end product requirements and generate a preliminary design for each system structure end product.</p>	System concept definition in the form of simulations, analysis, engineering models, and mockups and trade study definition
	B/C Design, Technology Completion and Fabrication	<ul style="list-style-type: none"> ● Baseline Design Solution and Trade Study ● Design and Build Technology Components ● Design Analysis and Report Results ● Peer Review (PDR) ● Test Technology ● Electromagnetic Interface, reliability and quality control ● System Integration Plan ● Finalize design ● CDR (Date) ● Key Decision Point (Date) to conclude Phases B and C <p>To complete the detailed design of the system (and its associated subsystems, including its operations systems), fabricate hardware, and code software. Generate final designs for each system structure end product.</p>	End products in the form of mockups, trade study results, specification and interface documents, and prototypes End product detailed designs, end product Component fabrication, and software development
Implementation			

Phase	Purpose	Typical Output
<p style="text-align: center;">D System Assembly, Integration and Test</p>	<ul style="list-style-type: none"> ● System Integration Review (Date) ● Fabrication completion ● Integrate components and Test ● System qualification verification ● Project Test ● Validate Project ● Operational Readiness Review (Date) ● Key Decision Point (Date) to conclude Phase D <p>To assemble and integrate the products to create the system, meanwhile developing confidence that it will be able to meet the system requirements. Launch and prepare for operations. Perform system end product implementation, assembly, integration and test, and transition to use.</p>	<p>Operations-ready system end product with supporting related enabling products</p>

3. The SDR Project: A Case Study for ASE Method

This section demonstrates application of the ASE method on the systems design process of a specific project of software defined radio (SDR). Systems design and the implementation processes of SDR project are comprehensively elaborated.

3.1 SDR Overview

The SDR project has been established between MSU’s Center of Excellence in Systems Engineering for Space Exploration Technologies (CESET) and NASA’s Goddard Flight Space Center (GFSC). The established joint effort is to develop the SDR project in order to produce technologies which will increase the speed, reliability, and range of communication between the ground and satellite stations.

The SDR project was a five-year long research project which started in Fall of 2008 and ended in the Fall of 2013. One of the goals of this program was to take initiative on conducting research which focused on technology development of solutions in SDR applications. These solutions would support GFSC’s space communication. The SDR project aimed to reach a technology capable of defining the signal through a digital means instead of the analog methods (Proakis, 1995). The SDR project would also allow centers to react quickly, and use a wider range of signals in order to transfer the data. Furthermore, it was designed to reduce analog system errors, speeding up communications especially in cases of emergency.

As a response to NASA’s solicitation for proposals calling for SDR technologies for space applications, CESET responded to the solicitation and attempted to provide a reusable system that can be implemented in NASA’s Tracking and Data Relay Satellite System (TDRSS). The CESET team consisted of faculty and students in Electrical Engineering, as well as Industrial and Systems Engineering departments. The CESET team had to employ the use of Systems Engineering methodologies to achieve the feat stipulated by NASA. The overall goal of the proposed research is to provide innovations in SDR (SDR) technology using frequency adaptive for analog front end and cognitive-based algorithms for RF front-end, smart power control, and smart waveform identification. Systems engineering team provided tools and methods that allows quantitative decision making for evaluating schedules. This project examined in-depth some of the Systems Engineering processes employed and explained the design process of SDR.

3.2 SDR Mission Objectives and Success Criteria

In an area where space exploration is becoming more common and missions to space are becoming more diverse, there are many challenges whose previous solutions are in need of improvement. One such challenge is the issue of communication between ground facilities, satellites and the ISS. SDR provides a significant improvement to past methods of space communications (Tuttlebee, 2002). SDR is a combination of hardware and software that will be installed in a satellite as a part of communications system which shall receive, amplify, down convert, demodulate, and decode the RF signal then return the response signal with efficient power for the ISS (Reinhart & Scardelletti, 2008). To have a schematic view of the following sections and sub-sections, Figure 3 in Section 2 may be consulted.

3.2.1 SDR Mission Objectives and Constrains

In order to make a strong mission statement, three categories and three steps within each of those categories have been suggested (Wertz & Larson, 1999). The name of each category and its steps are as follow. Defining objectives is the first category. In this category and within its three steps, broad objectives and constraints should be defined, and then quantitative mission needs and requirements should be estimated. The second category is to characterize the mission and its steps, including defining of alternative mission concepts, alternative mission architectures, and system drivers for each alternative. The third category is to evaluate the mission, and its steps comprise identifying critical requirements, evaluating mission utility, and finally, defining mission concept (Wertz & Larson, 1999).

After revising the existing preliminary mission statement, we finally obtained approval for this SDR project which is about conducting research initiatives that focus on technology development of solutions in SDR applications in support of GSFC communications as well as to develop SDR technology to expand the capability of a communication subsystem. More specifically, it aimed to develop spectrum sensing and dynamic allocation using agile RF components, to develop the ability to operate at multiple S-Band frequencies, and to develop the ability to optimize communication links based on dynamic link budget conditions using adaptive power control and RF components.

3.2.2 SDR Mission Success Criteria

Since SDR is only a testbed prototype, no environmental testing is required to be conducted by the MSU. Additionally, this system is the only available one for this purpose; therefore, all testing will be under the maximum stress ranges of base components. The scope of all performed tests determines functionality of the device at interface points and overall function of the SDR to accomplish the mission.

3.3 High Level Requirements SDR Technology Requirement

To have a schematic view of the following sections and sub-sections, we refer to Figure 3 in Section 2. The proposed requirements are elaborated in this section. MSU shall develop SDR Technology, which will be contained within a NASA satellite to improve the efficiency and effectiveness of docking with the ISS. ISS faces a number of challenges which includes the capacity to deliver cargo to the station and return it to earth in real-time.

The following Subordinate Requirements have been refined:

- SYS.1 Automated Rendezvous & Docking Scenario (Power Control)
- SYS.2 Autonomous Mode
- SYS.3 Frequency Agile
- SYS.4 Space Network Telecom/Single Access Services

The system structure is illustrated by the CORE (Vitech, 2013) software in Figure 4.

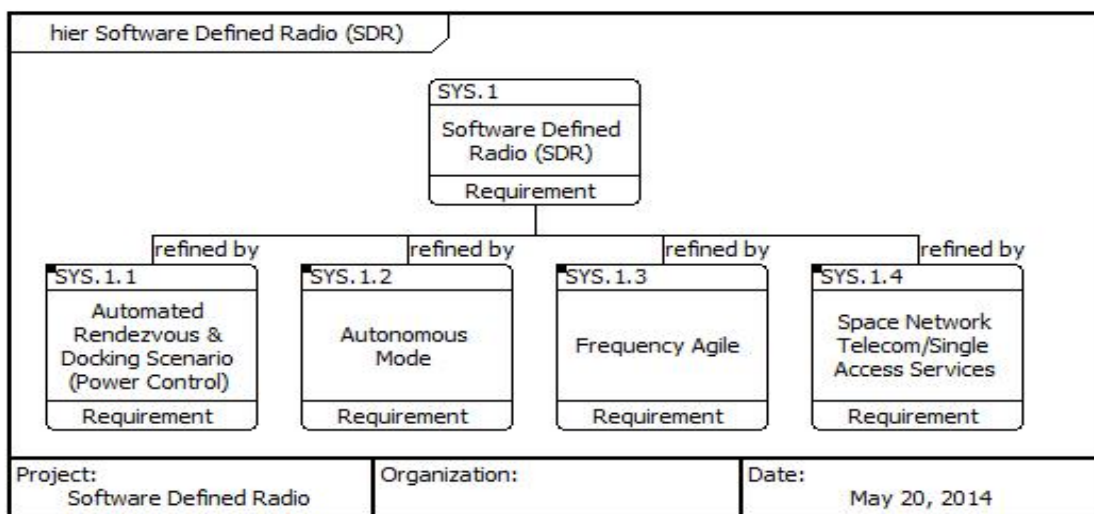

Figure 4. SDR System Structure

SYS.1.1 Automated Rendezvous & Docking Scenario (Power Control)

Requirement Statement:

The SDR technology shall be able to optimize performance based on range dynamics during the Automated Rendezvous & Docking Scenario. Optimization of system performance due to dynamics in transmission range may improve system reliability and enhance signal integrity.

SYS.1.2 Autonomous Mode

Requirement Statement:

The SDR technology shall be able to operate in autonomous mode. Autonomous functionality would enable new mission operations that will minimize the human-in-the-loop requirements and improve the reliability during contingency modes.

SYS.1.3 Frequency Agile

Requirement Statement:

The SDR technology shall be able to optimize performance based on frequency allocation. Efficient spectrum utilization is a prime directive of next-generation communication systems.

SYS.1.4 Space Network Telecom/Single Access Services

Requirement Statement:

The SDR technology shall be compatible with Space Network Telecommunication S-Band Single Access Services. All communication systems are mandated to be compatible with the NASA Space Network for the next-generation of space exploration and communication.

3.4 Functional and Logical Decomposition

3.4.1 SDR Functional

The function of the SDR is to operate at multiple S-Band frequencies to enable quicker and more efficient communications through the MSUSat. After the digital radio processes the signal received by the SDR, it will take into consideration the strength of the received signal, and will adjust its outgoing signal accordingly. SDR technology functions divide into four main functions (for a schematic view, see Figure 3 in Section 2):

- The function of Forward Link - to convert RF frequencies to IF frequencies.
- The function of the Digital Radio - to modulate and demodulate the IF signals that it receives.
- The function of the Return Link - to convert IF frequencies back to RF frequencies.
- The function of the Adaptive Power Amplifier - to appropriately adjust the power level of the signal being transmitted to the NASA testbed.

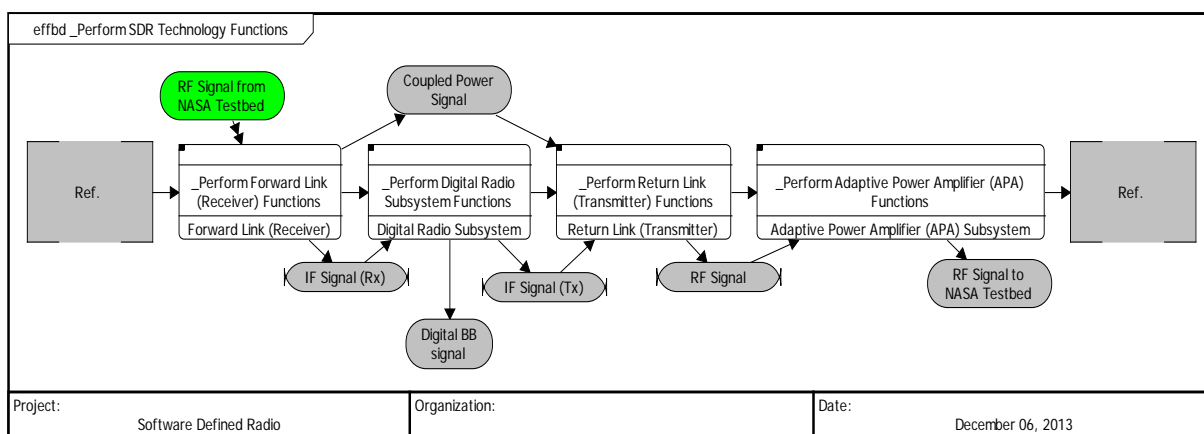

Figure 5. Perform SDR Technology Functions (Enhanced FFBD)

3.4.2 SDR Logical Decomposition
SDR Product Breakdown structure

This section covers first layer of Product Breakdown Structure (PBS) of the SDR. Blue color in a Physical Block Diagrams (PBD) indicates that those parts are not part of that system.

SDR Technology Description

The SDR Technology will increase the autonomous functionality within a receiver to meet multiple mission operations. The SDR Technology will have the ability to operate at multiple S-Band frequencies of agile RF components as well as the ability to optimize communication links based on dynamic link budget conditions such as adaptive power control and agile RF components.

Built From Lower-Level Component(s):

- SYS.1.1.1 RF Front-End Subsystem
- SYS.1.1.2 Digital Radio Subsystem
- SYS.1.1.3 Adaptive Power Amplifier (APA) Subsystem

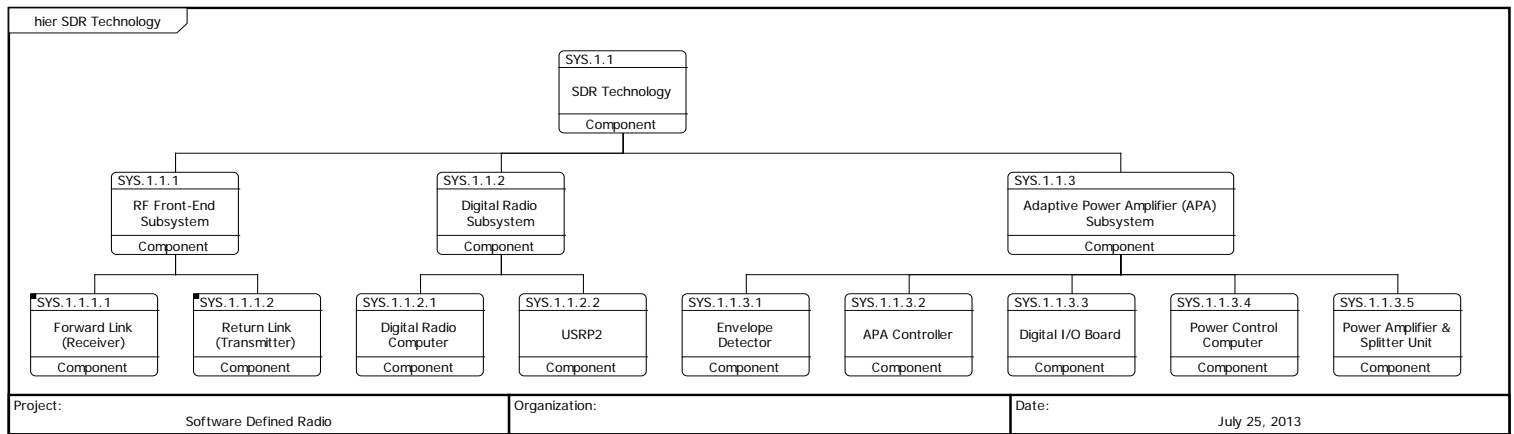

Figure 6. High level SDR Technology Component Hierarch

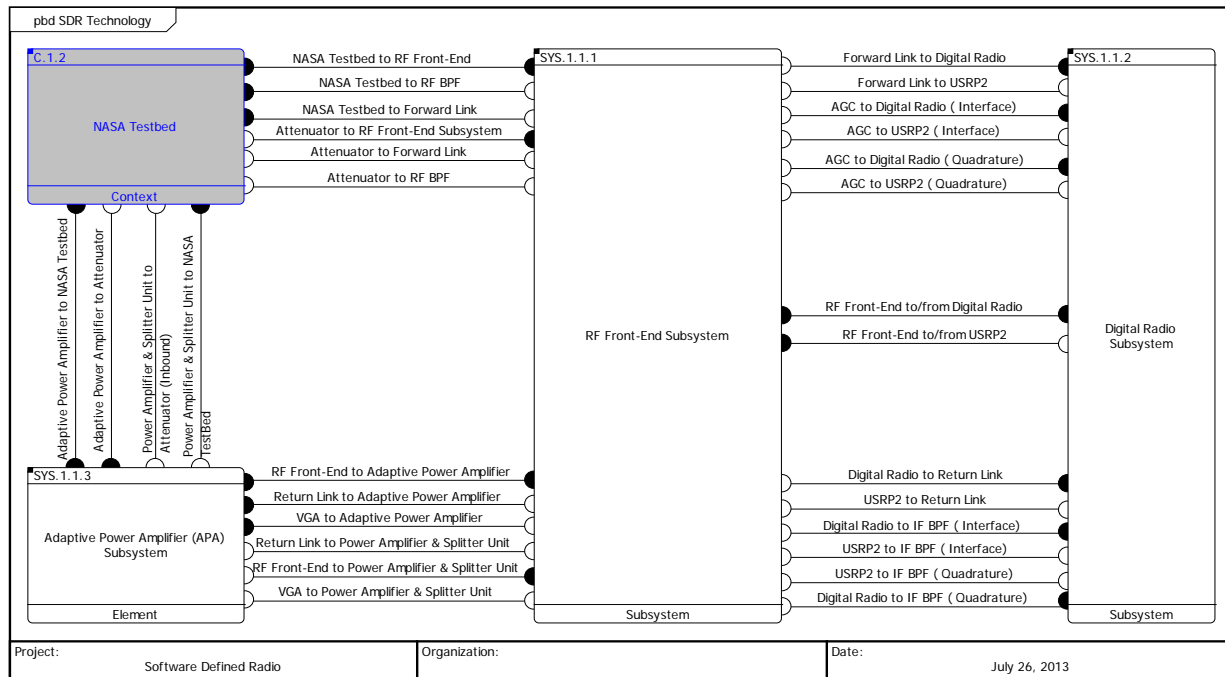

Figure 7. SDR Technology (Physical Block Diagram)

SYS.1.1.1 RF Front-End Subsystem

Description:

The RF Front-End is the area between the antenna and the digital radio. This area includes the forward and return link channels, which are made up of filters, amplifiers, and mixers. The RF Front-End takes signals received by the antenna and converts them into signals appropriate for input into the digital radio. Furthermore, the RF Front-End receives IF frequencies from the digital radio and converts it to an RF frequency to be sent out. The RF Front-End Subsystem should be able to handle a large signal bandwidth, broad dynamic output power range, broad dynamic input power range, and ample frequency ranges.

SYS.1.1.1.1 Forward Link (Receiver)

Description:

The Forward Link receives RF frequencies and converts them to IF frequencies while splitting the signal into an Interface channel and a quadrature channel to be sent to the digital radio (Hamkins & Simon, 2006).

SYS.1.1.1.2 Return Link (Transmitter)

Description:

The Return Link receives IF frequencies from the digital radio in an Interface channel and a quadrature channel and converts and combines them to an RF frequency.

SYS.1.1.2 Digital Radio Subsystem

Description:

The digital radio subsystem is a fully multi-functional, multi-band, multi-mode subsystem of the SDR. A digital radio processes sound into patterns of one and zeros. This differs from analog radio, which processes sound into patterns of electrical signals, in that it is more resistant to interference (Zafeiropoulos, 2003).

SYS.1.1.3 Adaptive Power Amplifier (APA) Subsystem

Description:

The adaptive power amplifier uses the distance between the SDR and receiver to properly amplify the signal to ensure its strength falls within a range which is acceptable to the receiver (Cripps, 1999).

4. Performance Comparison of the SDR Project Before and After ASE Method

In this section, the effect of application of ASE method on the SDR project is investigated. Performance of project development is compared between the first 2.5 years (Fall 2008 - Spring 2011) of the project with no systems engineering and the last 2.5 years (Spring 2011- Fall 2013) where the ASE method was applied. Chart below shows the major comparisons before and after our systems engineering effort.

Table 2. SDR Project Development Before and After Applying the ASE Method

Elements	First 2.5 years	Second 2.5 years
Project Structure		
• Mission Definition	Loosely defined	Redefined
• Concept of Operation	—	Defined
• Performance Requirements	Loosely defined	Redefined
• Functional Requirements	—	Defined
• Interfaces Requirements	—	Defined
• Product Breakdown Structure	Loosely defined	Redefined
• Project Life Time	—	Defined
• Project Process Flow	—	Defined
• Verification & Validation	—	Defined
• Documentation	—	Defined
Meeting Reviews		
• Internal Meeting Review	Every 2 month	2/month
• NASA - MSU follow up meeting	1/year	1/month
• Critical Meeting Reviews	—	Partially fulfilled
• Critical Meeting Reviews Criteria	—	Partially fulfilled

The improvements in individual elements mentioned in Table 2 are elaborated in the following sections. Two main factors which ASE method has focused are project structure and meeting reviews. First, accomplishments in defining and improving the project structure are discussed in details. Meeting reviews definitions and advancements are argued afterwards.

4.1 Project Structure

ASE method Project Structure covered the necessary technical systems engineering analyses generated for SDR project. Achievements in major parts of Project Structure are discussed below.

4.1.1 Mission Definition

The first issue that must be clearly and strongly defined at the beginning stage of every project is mission definition. The rest of any project is heavily dependent on the defined mission statement. It is rarely possible to come up with a strong mission definition without having knowledge of how to write a high-quality mission statement.

As the systems engineers (SE) joined the SDR project, the SE team had to revisit the preliminary mission statement. Its mission objective was loosely defined and it was very difficult to derive the precise goals of the project from the statement. On the other hand, success criteria were established. One issue that needed to be highlighted was that not only SDR project team leaders should approve the mission statement but also it has to be approved by SDR’s stakeholder or NASA.

4.1.2 Concept of Operation (ConOps)

A project may succeed only through robust ConOps stakeholder expectations, requirements, and the high level project architecture. ConOps is an important document that should apply for all projects to capture system characteristics as well as relation with outside world during the life-cycle phases to meet stakeholder expectations. In field of engineering, as an example, to achieve a successful mission, ConOps describes how the systems must technically operate. In our case study, ConOps gives an initial idea of how this new SDR technology will operate during its usage life. Unfortunately, lack of a comprehensive systems engineering knowledge was the reason for not addressing this important issue in early stages of SDR project. Thanks to direct help from NASA specialists, our team together was able to write the first comprehensive ConOps.

4.1.3 Performance / Functional / Interfaces Requirements

NASA has a large number of different requirements that should define for their projects. Although all of them can be important but not all of them are applicable in academic environment. Examples of some of those requirements that are not applied in the academia are safety requirements, human factor requirement, and government standard requirements. However, three main requirements should definitely be considered in academic projects: performance, functional, and interface requirements.

From our observation of SDR project, two team members out of three had worked on their requirements without collaborating with each other. Furthermore, the technical members who endeavored to write performance requirements did never approach functional requirements and only partially mentioned the interface requirements. Lack of knowledge on how the requirements should be defined made SDR members ignore this critical information. We worked together with the team members to edit and complete performance requirements. Eventually, we wrote the functional and interface requirements from scratch. One of the observations that highlights the role of systems engineers was that two subsystems interface requirements were not technically compatible and they had to redesign the circuit board to make the input-output subsystems compatible.

4.1.4 Product Breakdown Structure

Product breakdown structure is a helpful chart that shows all components used in the system, from system and subsystem level to the parts level. This information was not documented and shared with other team members. When the SE team got involved in the project, the only information available was that SDR contains three sub-systems: RF Front-End, Digital Radio, and Command & Control. Therefore, we were urged to complete these missing elements in project structure. First, we worked on the context diagram, the diagram that shows the relation of system with the outside world. We realized even breakdown of system needs some modification. For instance, adaptive power amplifier which originally was considered as part of a subsystem turned out to be its own subsystem due to its independent functionality. Using our proposed ASE method, SDR product breakdown structure ended up to contain sixty components in our final report.

4.1.5 Project Life Time

Project life cycle includes all the steps of project from beginning to the end. In real world projects, it is defined to be from concept studies to disposal. But, in contrast, academic projects only accomplished up to operation phase. Any project should include start point, end point, mission definition and success criteria for each phases of project. For SDR project, all these planning and success criteria definitions and check lists were established according our ASE method.

4.1.6 Project Process Flow

ASE method gave a guiding steps required to follow for team members to successfully perform the SDR project and complete the project in a systems engineering framework. Without following project process follow, the reliability of completing the project successfully was very low. For instance, a design should satisfy system requirements, and SDR project's mission. If we do not follow these requirements the final product would not satisfy stakeholders' expectations.

4.1.7 Verification & Validation

Verification and validation plan should be considered at the design stage. If this does not happen, later phases of a project may encounter serious problems. Therefore, in our SDR case, we had to go back to the original design and to find a test method to verify whether the design addresses client's expectations. Test plan is required for evaluation of system, thus in design stage, testing and evaluation should be considered. For example, in our ASE method, we proposed that SDR needs different numbers of power meters to check input and output power for validation.

4.1.8 Documentation

Documentation is very important for systems engineering discipline and it is considered as the key for long-term success. For example, high quality documentation is very helpful for future research project that are heavily based on current achievements. Preparing and documenting diverse aspects of systems engineering protocols are essential duty of a systems engineering team involved in a project. In SDR project, since systems engineering team was not defined in inception of the project it did not have any considerable documentation. We produced a comprehensive 300-page document that delivered along with the SDR product to NASA. The document was presented on hardcopy and digital file. For digital file other than PDF format, we passed the CORE version of data file for easy and fast access by systems engineers at NASA. Our document for SDR project included component overview, origination requirement, design constraints, performance requirements, functional behavior model, link designs and parametric designs, item dictionary, components, interface, requirement traceability matrix, and test plan.

4.2 Meeting Reviews

Meeting reviews are established for refreshing the partners involved in a project, either internal among technical or outside parties, specifically stakeholders. We categorized the meeting reviews to internal meeting reviews which is between team members, meeting reviews with stakeholders that are informal communications between technical team members, systems engineers, and technical team members of stakeholders, and finally, critical meeting reviews that are formal meeting reviews between all members of team project and all parties of stakeholders to decide the accomplishment of any phases.

4.2.1 Internal Meeting Reviews

Internal meeting reviews were accomplished, though sometimes were canceled due to schedule conflicts. Before our involvement as the systems engineering team, most of the meetings had no specific topic to be discussed other than financial management. After systems engineering engagement these meeting gradually elevated in both number and quality until we reached a two-meeting per month standard. Cultural habits were a resisting force against a quick increase in meeting numbers. For instance, some members indicated they could either focus on performing the technical tasks or attending the meetings. Indeed, in the beginning, technical members were not convinced that these meetings could in anyway help them on improving the project. This resulted in a situation that team leaders preferred to send their students to meetings and this drastically decreased performance of these meetings. After our efforts, the performance of the overall system significantly increased. For example, the system breakdown structure that we together came up with was very helpful for them to find out untouched areas that needed new efforts, such as sub-system compatibility and system evaluation.

4.2.2 NASA & MSU Informal Follow Up Meetings

As part of informal communications to follow up SDR project growth and test and verification, technical team members from MSU and NASA regularly had specific informal meetings. Yearly meetings were not enough to guarantee SDR project's success. Therefore, we established a monthly teleconference with NASA technical team members. Since it was an informal communication, both sides were much more comfortable and were able to ask questions that normally they hesitated to ask in a formal setting. On one side, NASA as the funder and client focused more on getting a clear idea of SDR's development level. On MSU's side, stakeholder's feedbacks were very helpful to understand NASA's expectation from the SDR team.

4.2.3 Critical Meeting Reviews

The only type of meetings that was establish between NASA and MSU was the annually meetings. Instead, ASE method presented a systematic evaluation system by establishing several critical meeting reviews with well-defined success criteria. We adapted and modified critical meeting reviews to be compatible with academic environment. Those meeting are MCR, SRR, PDR, CDR, SIR, and OPR, and their details are explained in Section 2.

5. Conclusions

The ASE method, introduced in this paper, is the first attempt to address such needs in the academia. There are many challenges in universities, such as lack of specifically-trained members for a new project, limited experimental and human resources, and loose connections among research laboratories with no hierarchical administrative structure. Knowing these challenges, ASE method initiated a user-friendly systems engineering paradigm for academic research teams involved in interdisciplinary large projects and the research specialist counterparts in funding agencies. This method is capable of guiding both technical and management aspects of a project. Indeed, applying this method on the SDR project strongly demonstrated its efficacy in improving the project's different aspects from defining its structure and system design process to meeting reviews and documentation of all its subsystems and phases.

There are some applications and future directions that may rise from this paper. First of all, this method may be applied on a variety of academic projects from the ones that only involve two laboratories to interdisciplinary projects that comprise diverse research teams to "megaprojects" that engage few major universities. Although the projects of various scales have their own systems engineering considerations but ASE method plays the role of a concise and convenient handbook that a representative from each research team should use it to shape a dialogue with representatives of other teams. In many cases, there will be no need for involvement of systems engineering teams into these projects and a good amount of acquaintance to ASE method makes the representatives self-sufficient.

However, one preliminary step for applying such methods in academic project is raising awareness about the importance of systems engineering discipline. There are many university departments and research centers as well as funding

agencies that are not aware of the existence systems engineering departments or even the concepts of systems engineering. This is partially because of the fact that systems engineering came to existence in major industrial companies and systems engineering faculties solely dealt with industry sector. Therefore, their accumulated knowledge did not transfer enough to scientists and researchers in other departments. But now with emergence of interdisciplinary movements in the academia, this accumulated knowledge and experience should be applied in the academic projects, too.

As a solution, systems engineering departments, university administrative systems, and specialists in federal agency may promote advocacy for implementation of systems engineering methods in collaborative academic projects. One barrier for such an advocacy is that no research has been done so far to quantify the budget loss due to lack of systems engineering framework. Statistics and field data may be very helpful for portraying an objective view of mismatches between federal investments in academic projects and the outputs of these projects that may not necessarily satisfy the agencies' original requirements. Therefore, defining very concrete criteria of success specifically for academic project seems very critical.

Another future direction can be the application of ASE method in small businesses and startup companies. There are many similarities between university research centers and small or newly formed companies. Indeed, many high-tech startup companies are inseminated from universities. A main common theme among these small companies is their lack of systems engineering knowledge. On the other hand, recruiting professional systems engineering teams is not affordable for them and reference to bulky systems engineering handbooks written for large companies may be quite frustrating for them. Here, suitable methods such as ASE may satisfy their needs from defining project process flow to establishing critical meetings and systematic documentations. This may be influential in increasing success rate of startup companies and expanding their entrepreneurship domain which ultimately result in the national development.

6. References

- Ave-Klutse Kodzo Paaku Kludze, J. (2003). *Engineering Of Complex Systems: The Impact of Systems Engineering at NASA*.
- Blanchard, B. S., & Fabrycky, W. J. (n.d.). *Systems Engineering and Analysis*.
- Buege, D. M. (2000). *The Engineering Design of System: Models and Methods*. New York: John Wiley & Sons. Inc.
- Damian, D. (2007). Stakeholders in Global Requirements Engineering: Lessons Learned from Practice. *IEEE*.
- Kasser, J., & Hitchins, D. K. (2011). Unifying systems engineering: Seven principles for systems engineered solution systems. *The 20th International symposium of the INCOSE*. Denver: INCOSE.
- Larson, & Wertz, W. (1999). *Space Mission Analysis and design*.
- Matthews, C. (2012). Federal Support for Academic Research. *Congressional Research Service*.
- NASA. (2007). NASA System Engineering Processes and Requirements (NASA Requirement Protocol). *NPR 7123.1A*.
- NASA. (2007). *NASA Systems Engineering Handbook*. Washington, DC: National Aeronautics and Space Administration , United States.
- NASA. (2014). *National Aeronautic and Space Administration*. Retrieved from [www. Nasa.gov](http://www.nasa.gov).
- Pohl, K. (2013). The Three Dimensions of Requirement Eengineering . *ESPRIT Basic Research Action 6353 Novel Approaches to Theories Underlying Requirements Engineering (NATURE)*.
- Proakis, J. G. (1995). *Digital Communications*. New York: McGraw Hill, Inc.
- Reinhart, R. C., & Scardelletti, M. C. (2008). Hardware Architecture Study for NASA's Space Software Defined Radios.
- Tuttlebee, W. H. (2002). *Software Defined Radio: Origin, Drivers, and International Prespectives*.
- Vitech, C. (2013). *CORE 8 Systems Engineering Guided Tour*. Retrieved from Vitechcorp.com.
- Vitech, C. (2014). Vitech Corporation. *CORE Benefits*. Retrieved from Vitechcorp.com.
- Wertz, W. J., & Larson, J. R. (1999). *Space Mission Analysis and design*.