

# Feeding the Needy through Feedback – A Systems Dynamics Analysis of New Jersey’s Supplemental Nutrition Assistance Program

Natalya Milian, Matthew Dabkowski, and Jonathan Mellon

Department of Systems Engineering  
United States Military Academy  
West Point, New York 10996

Corresponding Author's Email: [natalya.j.milian.mil@army.mil](mailto:natalya.j.milian.mil@army.mil)

**Author Note:** This paper was previously published and presented in the Donald R. Keith Memorial Capstone Conference at USMA in May of 2023. Cadet Milian is a fourth-year student in the Department of Systems Engineering at the United States Military Academy (USMA). Her thesis advisors are Colonel Matthew Dabkowski, Director of the Systems Engineering Program, and Dr. Jonathan Mellon, Assistant Professor in the Department of Systems Engineering. The views expressed herein are those of the authors and do not reflect the position of the United States Military Academy, the Department of the Army, or the Department of Defense.

**Abstract:** Social welfare initiatives in the United States strive to help as many people as possible with limited resources and within budgetary constraints. One such program is the Supplemental Nutrition Assistance Program (SNAP), colloquially known as food stamps, which provides income to people in need so they can purchase groceries. Although well-intended, critics of SNAP question not only its efficiency but also its efficacy due to its lack of access and inability to provide adequate benefits to its participants (Oliveira et al., 2018). This study models SNAP using systems dynamics, allowing us to examine these concerns and, when warranted, develop potential solutions. Specifically, we leverage the software Vensim to simulate New Jersey’s SNAP. Our findings suggest SNAP should focus its efforts on reaching the eligible population versus the program. These results are not merely academic; they are potentially actionable, as they can be used to reallocate existing funding.

*Keywords:* SNAP, Categorical Eligibility, Systems Dynamics

## 1. Introduction

### 1.1 SNAP – What Is It?

The Supplemental Nutritional Assistance Program (SNAP) seeks to provide nutritional assistance to people below a certain income threshold. Affecting a multitude of households from varying backgrounds across the United States, SNAP is not reserved for those who are unemployed or do not want to be employed. It can be for anyone who has encountered a difficult financial time in their life, including public servants. For example, in 2019 there were 22,000 active-duty service members and 213,000 National Guard members or Reservists on SNAP (USDA Contributors, 2022). Moreover, this number is likely to have increased since 2019 due to inflation and comparatively minor increases in military pay. SNAP is also essential to the rest of American society, especially in times of recession. A 2003 study of SNAP found that a 4% increase in the unemployment rate due to a long recession can cause a 15% increase in food stamp caseload, showing SNAP’s ability to affect change in people’s lives (Figlio, Gundersen & Ziliak, 2003). Like any social welfare initiative, SNAP is supported by limited resources and subject to budgetary constraints. Accordingly, efficiency is paramount when it comes to feeding as many people as possible.

There are three main functions of SNAP: provide supplemental assistance to meet nutritional needs, provide job training services to help recipients climb out of poverty, and enforce eligibility rules to ensure beneficiaries do not abuse the system. To qualify for SNAP, a person must undergo the process outlined in Section 1.2 to determine their eligibility. Once a person is deemed eligible through SNAP’s income maintenance department, which processes their application, they receive a monthly stipend on an electronic benefit transfer (EBT) card for certain food items at one of 254,000 retailers (CPBB Contributors, 2022). This EBT card cannot be used to purchase non-food items, including hot foods that are already prepared, alcohol, cigarettes, or vitamins (CPBB Contributors, 2022). The SNAP department that handles job training services is referred to as the employment and training program, which helps SNAP participants build resumes and create job applications to increase their chances of gaining quality employment (USDA Contributors, 2022). Finally, SNAP’s investigation department takes legal action to help ensure that (a) only eligible individuals receive benefits and (b) eligible individuals who are receiving benefits are spending their stipends on the right items with the right retailers.

SNAP is funded by both state and federal governments, with New Jersey’s most recent state contribution being \$20.5 million (McKnight, 2022). The federal government spends far more: a staggering \$111 billion in fiscal year 2021 for SNAP

across the United States (CPBB Contributors, 2022). Clearly, SNAP is both expensive and impactful, making it necessary to verify that the money allocated to the program is spent efficiently and effectively.

## 1.2 SNAP – Determining Eligibility

States can implement SNAP through federal income levels or categorical eligibility, which includes traditional, narrow, and broad-based versions (Aussenberg and Falk, 2022). To meet federal income levels, a household must earn less than 130% of the federal poverty level, or \$2,379 per month, for fiscal year 2022 (Aussenberg and Falk, 2022). Some states, such as New Jersey set higher cutoffs, allowing households to qualify for SNAP benefits if they earn below 185% of the federal poverty level (LSNJLaw Contributors, 2022). Once a household falls below this monthly gross income threshold, they can apply for SNAP benefits.

Under the categorical eligibility method, a person automatically qualifies for SNAP if they qualify for some other state benefit, such as Temporary Assistance for Needy Families (TANF) or Supplement Security Income (SSI). Broad-based categorical eligibility ensures more people qualify for SNAP, while narrow-based categorical eligibility ensures fewer people qualify (Aussenberg and Falk 2022). Currently, 44 states, including New Jersey, use broad-based categorical eligibility, and most states grant SNAP eligibility to households referred through TANF, without a lengthy application process (Aussenberg and Falk, 2022).

A household must notify their local SNAP office if its income increases dramatically, and it must reapply for SNAP benefits every six to twelve months at the earliest (CPBB Contributors, 2022). This reapplication process is in place to ensure households that are ineligible for SNAP do not continue to unnecessarily use the program's money. Nonetheless, lengthy reapplication windows, self-reporting, and automatic enrollment create conditions favorable for erroneous overpayment, providing ample reason and opportunity for oversight.

## 1.3 SNAP Program – Tradeoffs

Most of the current literature on SNAP is largely positive. One study found SNAP reduced food insecurity by 8.6% nationwide from 2019 to 2021, despite the COVID-19 pandemic, by increasing the program's accessibility and issuing a temporary 15% increase in benefits when the pandemic began (Brady et al., 2023). Unfortunately, the current literature does not tell the full story. A study conducted found that nearly 60% of households surveyed who were eligible for SNAP never applied because they perceived themselves to be ineligible for the program (Daponte, Sanders, & Taylor, 1999). On the other hand, there are people who receive benefits or could benefit from doing so; however, their stipend is either too small or their income is just above the federal poverty level. For example, 10% of food stamp recipients reported that they did not eat food for a day, and 18% were hungry but unable to eat for a lack of money (PSID Contributors, 2019). The literature also ignores people who receive benefits when they should not be due to underreported incomes or undeclared monetary gifts from friends and family. Additionally, some retailer owners will exchange individuals on SNAP a cash percentage of their food stamp benefit so the store owner can buy food for themselves using the benefit and the individual can make unauthorized purchases rather than the food they need. An egregious example of this is from a store owner in New Jersey who unlawfully exchanged \$4.5 million worth of food stamp benefits from January 2014 to January 2018 (US Attorney's Office Contributors, 2021). While cases like these are rare, they still waste an incredible amount of taxpayer money when they do happen.

In fiscal year 2021, the federal government allocated 94.3% of SNAP funding for households to purchase food; 5.3% for state administrative costs, such as determining a SNAP household's eligibility for employment, training, and nutrition education; and the remainder for ensuring people were not abusing the program through anti-fraud efforts (CBPP Contributors, 2022). Due to the volume of people who receive SNAP assistance and the small number of government employees who allocate the money, there are households that slip through the cracks and receive benefits, causing others to miss out on benefits they should be receiving. Only 82% of eligible SNAP participants across the United States are enrolled in the program, showing improvements can be done for SNAP's outreach to America's food-insecure population (FNS Contributors, 2023). While SNAP has helped many families in America and is a great program to ensure people remain fed, it is a temporary solution to a problem requiring a permanent solution. In a study conducted from 2009 to 2012, it was found that 39% of SNAP participants were on the program for 3 to 4 years, while only 30% of SNAP participants were on the program for no more than one year (Irving, 2015). The employment and training program is meant to reduce the time individuals spend receiving food stamps, but because participation is not mandated people do not take advantage of its existence to find quality work so they can remove themselves from SNAP (NJ SNAP Contributors, 2023). To this end, some options are periodically checking a household's income to determine continued eligibility, mandating participation in the employment and training program for participants to find quality jobs that push them above the federal poverty guidelines and increasing the number of SNAP enforcement personnel. Intuitively, it seems likely that a balance between these three areas could improve SNAP's efficiency and effectiveness. This study seeks to prove it.

## 2. Methodology

### 2.1 The Systems Dynamics Modeling Process

Systems dynamics modeling follows five steps: articulating the problem, formulating a dynamic hypothesis, formulating a simulation model, testing, and policy design and evaluation (Sterman, 2000). A summary of these steps follows, and a detailed description is available upon request .

#### 2.1.1 Problem Articulation

The problem articulation step of the systems dynamics modeling process for SNAP began in Section 1. It was facilitated by an extensive literature review and an interview with a government employee from SNAP’s income maintenance department, who provided an in-depth explanation of how the program operates. To reiterate, the purpose of this study is to find a more efficient or effective way to allocate SNAP’s budget to its different subprograms so people can permanently exit the program to avoid receiving assistance indefinitely. Figure 1 outlines a general method of describing the key endogenous, exogenous, and excluded variables within the stock and flow diagram for SNAP. The endogenous variables control how the different SNAP departments impact the stocks and their associated flows. The exogenous variables were kept exogenous to simplify the model, but they can become endogenous with the inclusion of additional variables that affect their behavior. Similarly, the excluded variables were excluded from the model in the spirit of parsimony, but they represent opportunities for future work, such as investigating how underreported income and incorrect spending affect the system. The time horizon is 60 months, evaluated monthly, providing ample opportunity to see how policy changes in SNAP’s income maintenance, employment and training, or investigation departments affect how many people are on food stamps, both correctly and incorrectly, in the short term and over the long run.

#### 2.1.2 Formulating a Dynamic Hypothesis

This model seeks to find an effective allocation of funds to SNAP’s departments, so they can reach and provide aid to all eligible households. The goal is to improve the recipients’ quality of life by providing them with the food stamp benefits and the resources necessary to increase their incomes beyond SNAP’s eligibility thresholds. The dynamic hypothesis for this study is if the resources allocated to the income maintenance, employment and training, or investigations departments increase, the overall amount of people on food stamps will decrease. The greatest decrease will be experienced by unemployed people who are eligible for and on food stamps because they will either (a) find a job through the jobs program and remain on food stamps or (b) find a job through the jobs program and no longer be eligible for SNAP. The people who are ineligible for, but on food stamps, will also decrease because the investigation department will be able to catch more people abusing the system. That said, there will likely always be a small percentage of people abusing the system, as it is difficult to catch someone underreporting their income, and it becomes more costly to seek these people out than to simply (and erroneously) leave them in the program.

Endogenous	Exogenous	Excluded
<ul style="list-style-type: none"> <li>• Money Spent on the Different Departments</li> <li>• Number of Employees in Each Department</li> <li>• Correct Employed/Unemployed Disenrollment Fractions</li> <li>• Maximum Application/Investigation Capacity</li> <li>• Monetary Punishment for Remaining Enrolled</li> <li>• Total Spent per Month on Ineligible People</li> <li>• Number of True/False/Total Allegations</li> <li>• Success Rates of Each Department</li> <li>• Total Number of Food Stamps</li> </ul>	<ul style="list-style-type: none"> <li>• Average Time for Employed/Unemployed to Apply</li> <li>• Average Applications/Investigations Processed per Employee per Month</li> <li>• Average Money Spent on Different Aspects of Each Department</li> <li>• Fractions of Individuals that Flowed Between Stocks</li> <li>• Fractions of Individuals that Lose their Jobs</li> <li>• Fractions of Individuals that Enter/Exit Poverty</li> <li>• Fractions of Individuals Gaining/Losing their Eligibility/Benefits</li> <li>• Average Monthly Food Stamp Benefit</li> <li>• Federal and State Contributions</li> </ul>	<ul style="list-style-type: none"> <li>• Fraction of Individuals Underreporting their Income</li> <li>• Fraction of Individuals who Received Benefits through Broad-Based Eligibility</li> <li>• Individual Satisfaction with SNAP Benefit</li> <li>• Effort Allocated to Each Investigation</li> </ul>

Figure 1. General Key, Exogenous, and Excluded Variables

#### 2.1.3 Formulating a Simulation Model

The stock and flow diagram for SNAP is shown in Figures 2 through 6, with model assumptions denoted in green. For a comprehensive model description, contact the corresponding author. The model was developed using Vensim software and can be simulated over time to evaluate policy changes. Figure 3 denotes SNAP’s five stocks as rectangles, along with their associated flows. From left to right, these five stocks are (1) *people ineligible not on food stamps*, (2) *people eligible not on*

*food stamps*, (3) *people employed and eligible on food stamps*, (4) *people unemployed and eligible on food stamps*, and (5) *people ineligible on food stamps*. The *people eligible and on food stamps* are divided into employed and unemployed stocks to visualize the impact of the employment and training department on the flow of people between the stocks. The *people ineligible not on food stamps* stock has four inflows and two outflows, the *people employed and eligible on food stamps* and *people unemployed and eligible on food stamps* stocks have three inflows and four outflows, and the *people eligible not on food stamps* and *people ineligible on food stamps* have three inflows and three outflows each. When constructing the flows between stocks, each possible flow from an origin stock to one of the other four destination stocks was considered. Some flows were deemed infeasible because there was no possible way for some stocks to connect, as the flow of population would likely shift to another stock before entering the destination stock. For example, it is assumed *people eligible not on food stamps* could not flow to *people ineligible on food stamps* or vice versa, because in continuous time a person's eligibility and participation status in the program cannot change simultaneously. This also applies to the stock of *people ineligible not on food stamps* not flowing to *people employed and eligible on food stamps* or *people unemployed and eligible on food stamps*.

Figure 2 shows how the income maintenance department affects the stocks in Figure 3. The income maintenance department only influences the flows from the *people eligible not on food stamps* stock to the *people employed and eligible on food stamps* and *people unemployed and eligible on food stamps* stocks. As the number of *income maintenance staff* increases and their ability to process applications increases, the *maximum application capacity* will also increase to allow more *people eligible not on food stamps* to apply and gain access to SNAP. Allocating additional resources to the income maintenance department would be the best way to increase the *number of income maintenance staff* and the *average applications processed per employee per month*.

Figure 4 depicts the structure of the employment and training department and its effects on the stocks from Figure 3. The employment and training department only affects the flows leaving the *people unemployed and eligible on food stamps*, which is the target population for the jobs program. The *jobs program success rate* is measured as a function of how many unemployed participants are enrolled in the jobs program and how long it takes these participants to find a job following their enrollment. This influences the overall *finding jobs rate* and the *individual finding job success rate*, which subsequently influences the rate of an individual finding a job and keeping their SNAP eligibility versus finding a job and losing their SNAP eligibility. Like the income maintenance department, as the *jobs program staff* increases, the *jobs program staff to participant ratio* decreases. This makes the overall program more effective, as additional staff lower the average time for an individual to find a job while enrolled in the jobs program.

Figure 5 depicts the investigations department's effect on the stocks of the model. The investigation department only affects the flow from the *people ineligible on food stamps* stock to the *people ineligible not on food stamps* stock. Its performance is measured by how many investigations are completed compared to the proportion of true allegations within the program. The *maximum capacity of investigations* is modeled similarly to the income maintenance department's *maximum application capacity* in Figure 2. In this case, the *average number of investigations completed per employee per month* and the number of *investigation department staff* comprise the *maximum capacity of investigations*. The *proportion of true allegations* is influenced by the *number of true allegations* versus the *number of false allegations* reported, which are influenced by the *fractional true allegation rate* and *fractional false allegation rate*, along with the stocks of the *people ineligible on food stamps* versus the *people eligible and on food stamps*. Once again, as the department's staff and resources increase, its *maximum capacity of investigations* increases, thereby increasing the number of ineligible people who are caught and removed from the program.

Figure 6 depicts how money, the primary resource of SNAP, flows through the model. The *state and federal contributions* to the program increase SNAP's operating budget (*money received*), while the total *money spent on food stamps* and the *money spent on the income maintenance department, jobs program, and the investigations department* capture SNAP's expenditures (*money spent*). The money spent on each department is influenced by the number of employees in the department, the average salary of these employees, and the resources spent to complete the specific function of the department. This section of the model allows us to identify the most expensive elements of SNAP, which represent potential opportunities for process improvement initiatives and policy changes.

### 2.1.4 Testing

Figure 7 shows how the people in each stock of the system flow over the 5-year time horizon. As shown, most of the stocks experience a gradual increase or decrease throughout the simulation. To begin, *people eligible not on food stamps* increases gradually, beginning with 225,000 people and reaching 970,000 people by the end of the simulation. *People employed and eligible on food stamps* exhibit similar behavior, ending at 1.28 million people after beginning with 370,000 people. *People unemployed and eligible on food stamps* do the opposite, beginning at nearly 475,000 people and decreasing significantly to 175,000 people. This indicates that many *people unemployed and eligible on food stamps* transitioned to *people employed and eligible on food stamps* through gaining employment, likely due to the success of the employment and training program.

Interestingly, *people ineligible on food stamps* begins at about 60,000 people, decreases rapidly within the first five months to 3,000 people, and slowly increases for the remainder of the simulation until it reaches just about 5,500 people. This is likely because it is much easier to detect people incorrectly using the system when there are more people doing so and it becomes increasingly difficult to detect these people as this population decreases. *People ineligible not on food stamps* begins at 8.1 million people and decreases to 6.8 million people, indicating that many people who were ineligible for food stamps when the simulation began, transitioned to being eligible for food stamps once the simulation ended. This is the most troubling change within the simulation, as the *people eligible not on food stamps* population is the population in the greatest need because they currently are not receiving assistance for their situation. Policy design and evaluation should test SNAP changes that address this issue, along with the issue of the *people ineligible on food stamps* increasing after the 5-month mark of the simulation.

### 2.1.5 Policy Design and Evaluation

The policy design and evaluation portion of this study tested policies that focused on reallocating SNAP resources and evaluating their effects on the stocks' fluctuations over time to help inform how resources could be efficiently and effectively redistributed. The specific policies tested involved increasing the punishment associated with abusing the system, increasing the resources allocated to the different departments, and mandating 100% participation in the jobs program. The first policy of increasing the punishment associated with abusing the system had a negligible effect on the *people ineligible on food stamps* once the punishment exceeded \$1,000. Regardless of this policy change, the *people ineligible on food stamps* exhibited the same behavior discussed in the previous section of increasingly slightly for the rest of the simulation after its rapid, initial decrease. The second policy of reallocating resources to the different departments yielded interesting results. Doubling the employment and training program and investigations departments' staffs resulted in no change to the stocks, whereas doubling the income maintenance department resulted in a positive change to all stocks except *people ineligible on food stamps*, where it facilitated no change. Doubling the staff in all three departments simultaneously caused no change beyond doubling the income maintenance department's staff, showing that resources should be prioritized to the income maintenance department to improve the efficiency of SNAP. An unfortunate side effect of implementing this policy change is that it created nearly a \$7 billion budget, which is highly infeasible for one state, let alone all states. The third policy of mandating 100% participation in the employment and training program resulted in no change to any of the stocks. Simply put, in order to improve the ability of SNAP to reach those in need, the federal and state government should look for other methods of funding this massive program.

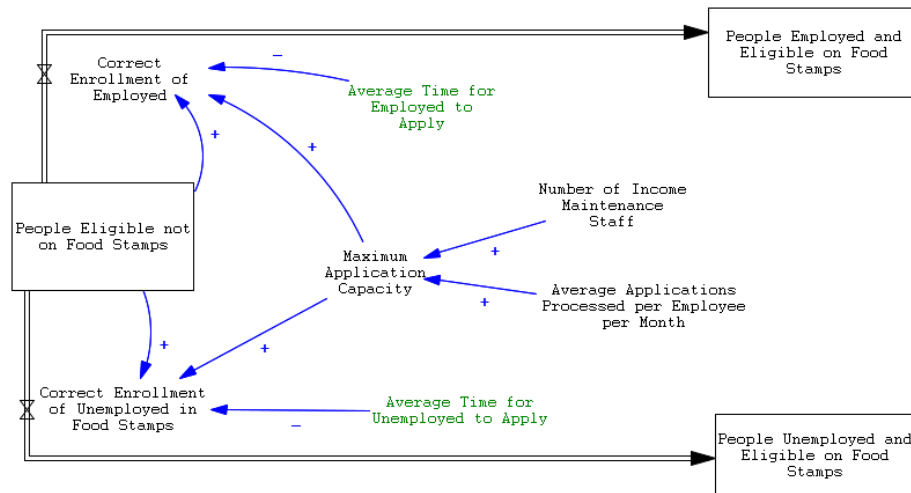

Figure 2. Stock and Flow Diagram for the Income Maintenance Department. The blue arrows represent causal links between variables, while the addition/subtraction signs indicate a directly or inversely proportional relationship respectively.

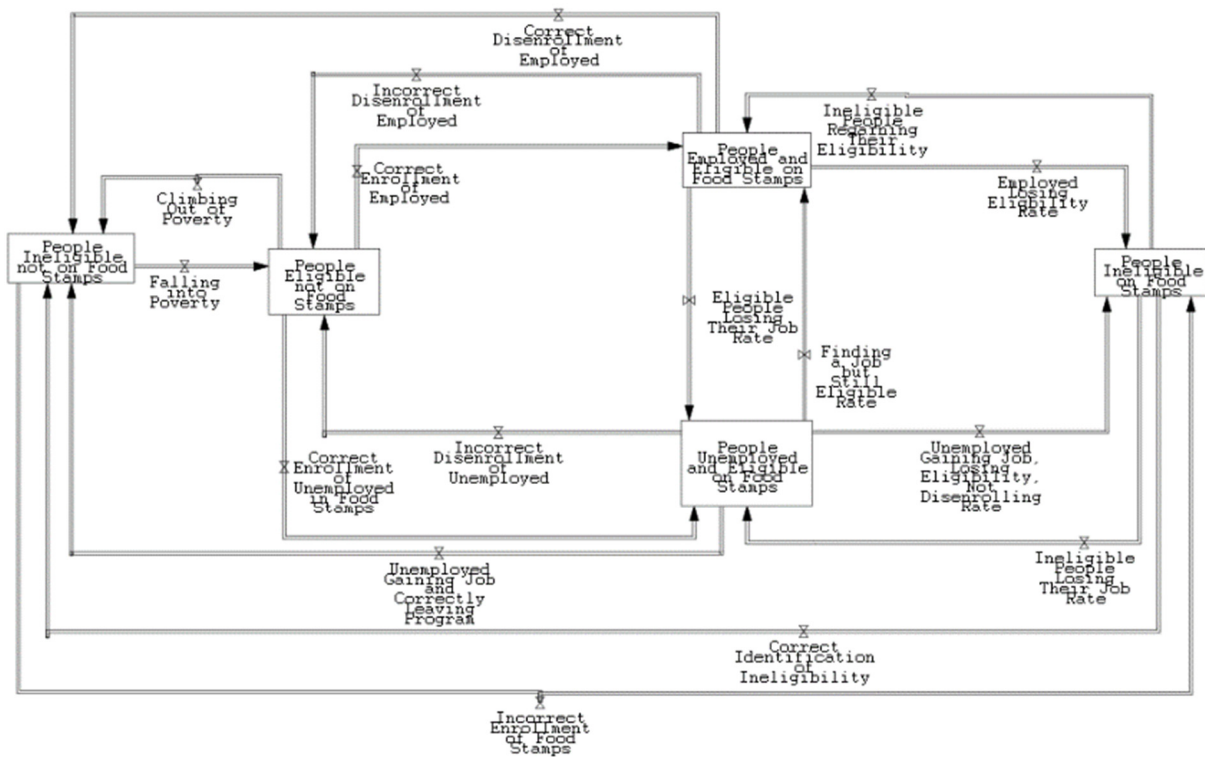

Figure 3. Five Mutually Exclusive and Collectively Exhaustive Stocks and their Associated Flows

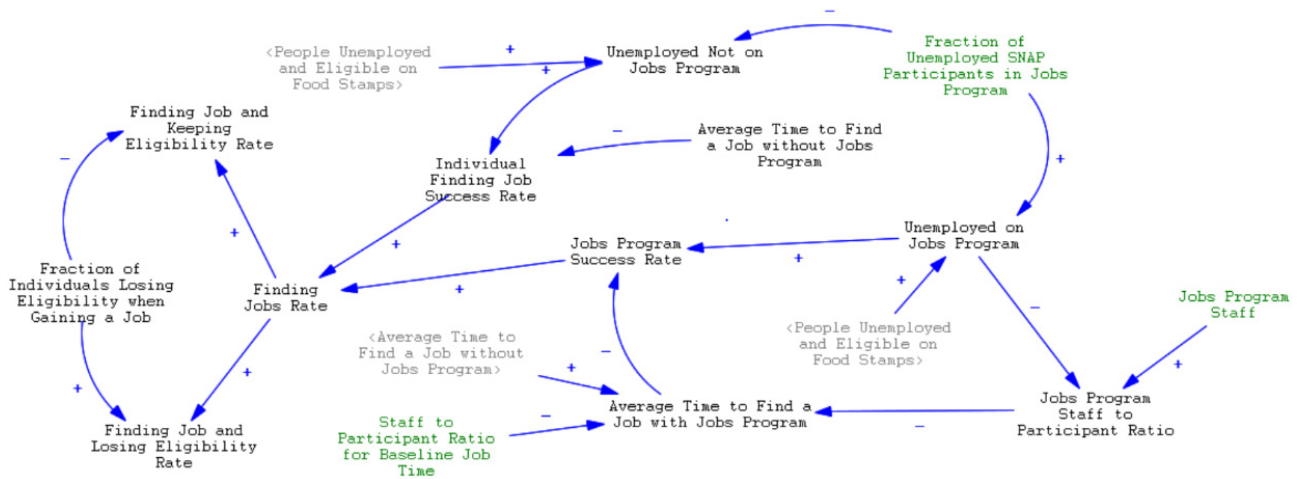

Figure 4. Stock and Flow Diagram for the Employment and Training Department

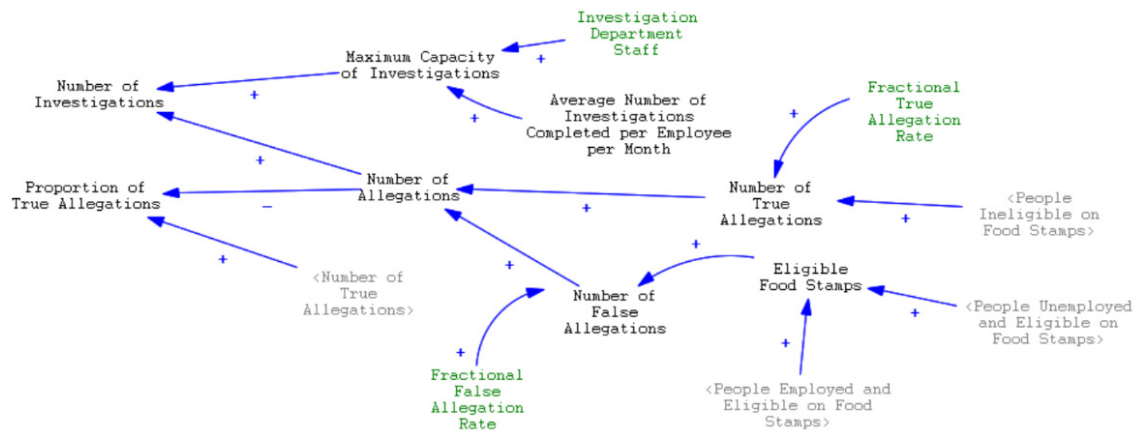

Figure 5. Stock and Flow Diagram for the Investigations Department

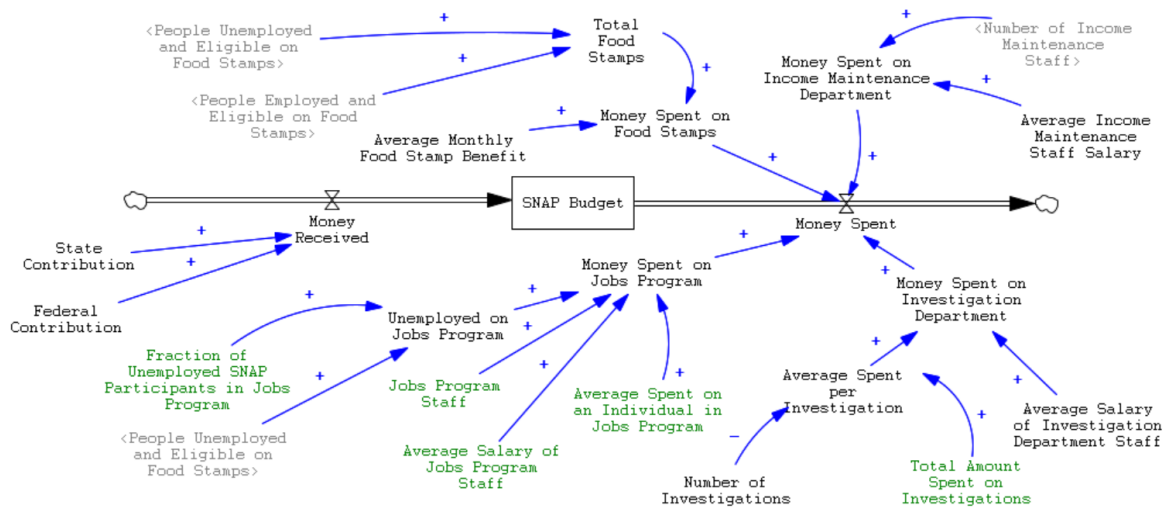

Figure 6. Stock and Flow Diagram for the SNAP Budget

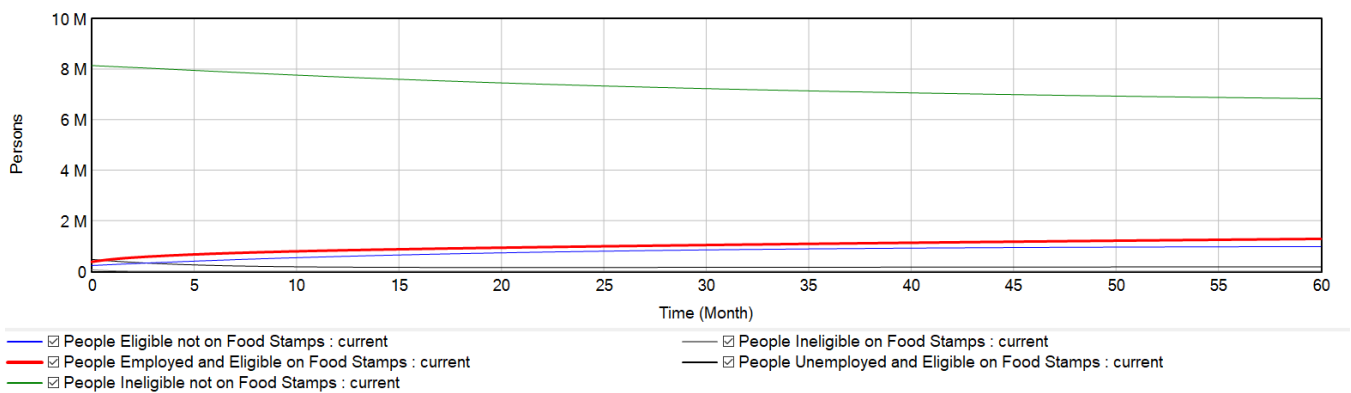

Figure 7. Interactions of the Stocks over Five Years

### 3. Conclusions & Future Work

Systems dynamics is a powerful tool for modeling complex problems with interacting variables that produce feedback. When applied to New Jersey's SNAP, it can be used to develop insights that support or oppose potential policy changes. As discussed in Section 2.1.4, the simulated stock and flow model shows that the greatest issue lies in the fact that once a person enters poverty and is deemed eligible for food stamps, it becomes incredibly difficult for them to exit poverty, even if they receive food stamps. It may be helpful for SNAP administrators to increase the food stamp benefit allocated to eligible people, to give them the supplemental income they need to eventually exit poverty. To efficiently help the most people possible though, state and federal governments must allocate more money to SNAP to avoid a gross budget deficit.

Future work should validate the results found in Section 2.1.4 by interviewing SNAP employees for estimates of the model's five stocks. This study could also be improved by exploring different methods of funding SNAP to avoid a budget deficit with policy implementation. Additionally, it may be helpful to model SNAP's interaction with other welfare programs, such as the previously mentioned TANF and SSI, as most recipients of SNAP are also involved in these programs. This may provide more accurate data on how the stocks flow between each other and may help to avoid a budget deficit. Finally, some variables within the model are based upon assumptions that could benefit from more robust research or more recent data. Addressing these issues should increase the model's accuracy and facilitate future policy design and evaluation.

### 4. References

- Aussenberg R. A., & Falk G. (2022). The Supplemental Nutrition Assistance Program (SNAP): Categorical Eligibility. Congressional Research Service. <https://sgp.fas.org/crs/misc/R42054.pdf>
- Brady P. J., et al. (2023). Food Security Among SNAP Participants 2019 to 2021: A Cross-Sectional Analysis of Current Population Survey Food Security Supplement Data. <https://doi.org/10.1017/jns.2023.32>
- CBPP Contributors. (2022). Policy Basics: The Supplemental Nutrition Assistance Program (SNAP). Center on Budget and Policy Priorities. <https://www.cbpp.org/research/food-assistance/the-supplemental-nutrition-assistance-program-snap>
- Daponte, B. O., Sanders, S., & Taylor, L. (1999). Why Do Low-Income Households not Use Food Stamps? Evidence from an Experiment. *The Journal of Human Resources*, 34(3), 612-628. <https://doi.org/10.2307/146382>
- Figlio, D. N., Gundersen, C., & Ziliak, J. P. (2003). Food Stamp Caseloads over the Business Cycle. *Southern Economic Journal*, 69(4), 903-919. <https://doi.org/10.2307/1061657>
- FNS Contributors. (2023). SNAP Participation Rates by State, All Eligible People. US Department of Agriculture. <https://www.fns.usda.gov/usamap#>
- Irving, S. K. (2015). How Long Do People Receive Assistance?. United States Census Bureau. <https://www.census.gov/newsroom/blogs/random-samplings/2015/05/how-long-do-people-receive-assistance.html>
- LSNJLaw Contributors (2022). SNAP – New Jersey's Food Stamp Program. Legal Services of New Jersey. <https://www.lsnjlaw.org/government-aid-services/food-hunger-nutrition/food-stamps/pages/snap-nj-food-stamp-program.aspx>
- NJ SNAP Contributors. (2023). SNAP Employment and Training Program (SNAP E&T). New Jersey Department of Human Services. <https://www.nj.gov/humanservices/njsnap/recipients/training/>
- Oliveira, V., Prell, M., Tiehen, L., & Smallwood, D. (2018). Design Issues in USDA's Supplemental Nutrition Assistance Program: Looking Ahead by Looking Back. US Department of Agriculture. [https://www.ers.usda.gov/webdocs/publications/86924/err-243\\_summary.pdf](https://www.ers.usda.gov/webdocs/publications/86924/err-243_summary.pdf)
- PSID Contributors. (2023). *PSID Main Family Data* [Data set]. <https://simba.isr.umich.edu/DC/f.aspx>
- Sterman, J. D. (2000). *Business Dynamics: Systems Thinking and Modeling for a Complex World*. Boston, Massachusetts: Irwin McGraw-Hill.
- US Attorney's Office Contributors. (2021). Passaic County Couple Sentenced for Roles in \$4.5 Million Food Stamps Fraud Scheme. US Department of Justice. <https://www.justice.gov/usao-nj/pr/passaic-county-couple-sentenced-roles-45-million-food-stamps-fraud-scheme>
- USDA Contributors. (2022). Food and Nutrition Service: Military and Veteran Families. US Department of Agriculture. <https://www.fns.usda.gov/military-and-veteran-families>
- USDA Contributors. (2022). The Use of Supervised Job Search, Job Search Training, and Integrated Job Search in USDA SNAP E&T: Three Case Studies. US Department of Agriculture. <https://www.fns.usda.gov/snap/job-search-employment-training-case-studies>